

Maxsine

EP1C Plus series

AC servo driver

Operating Instructions

(9th Edition)

Driver TL01/TL02/TL05/TL08/TL10/TL15/TL25/TL35/TL55
TH06/TH10/TH15/TH20/TH30/TH50/TH75/TH90
TH110/TH150

Wuhan Maxsine Electric Technology Co., Ltd



DECLARATION

Wuhan Maxsine electric technology limited company all rights reserved.
Without this company's written permission, forbid strictly the reprint either the part or the complete content of this handbook.

There will not be extra notice if the specification or size of products is changed because of improvement etc.

Safety Precautions

In order to ensure proper use of this product safely, the user should be familiar with and observes the following important items before proceeding with storage, installation, wiring, operation, inspection or maintenance for the product.

 Danger	Indicates a disoperation possibly can cause danger and physical injure or death.
 Caution	Indicates a disoperation possibly can cause danger and physical injure, and may result in damage to the product.
 Stop	Indicates a prohibited actions, otherwise can cause damage, malfunction to the product.

1. Use occasions

 Danger
<ul style="list-style-type: none">● Do not expose the product in moisture, caustic gas, and ignitable gas situation. Otherwise can cause an electric shock or fire.● Do not use the product in direct-sunlight, dust, salinity and metal powder places.● Do not use the product in the places that has water, oil and drugs drops.

2. Wiring

 Danger
<ul style="list-style-type: none">● Connect the earth terminal (PE) to earth reliably, otherwise can cause an electric shock or fire.● Do not connect 220V driver to 380V power supply. Otherwise it will cause equipment damage, electric shock or fire.● Do not connect the servo motor output terminals (U, V, W) to 3 phase AC power supply, otherwise can cause personnel casualty or fire.● The output terminals (U, V, W) must be connected with the servo motor connections (U, V, W) correspondently, otherwise can result in the motor flying speed that may cause equipment damage and the personnel casualty● Please fasten the input power terminals (L1, L2, and L3) and the output terminals (U, V, W). Otherwise may cause fire.● Referring to wire selection guide, please install all wires with an adequate cross-section. Otherwise may cause fire.

3. Operation

 **Caution**

- Before operating the mechanical device, it is necessary to set the parameters with appropriate values. Otherwise, can cause the mechanical device to out of control or break down.
- Before running the mechanical device, make sure the emergency stop switch can work at any time.
- Performing trial run without load, make sure that the servomotor is in normal operation. Afterwards joins again the load.
- Please do not turn on and off the main power supply more frequently, otherwise can cause the servo driver overheat.

4. Running

 **Stop**

- Do not touch any moving parts of the mechanical device while the motor is running, otherwise can cause personnel casualty.
- Do not touch driver and motor while the equipment is operating, otherwise can result in an electric shock or scald.
- Do not move any connection cables while the equipment is operating, otherwise can result in physical injure or equipment damage.

5. Maintenance and inspection

 **Stop**

- Do not touch any portion inside of the driver and motor, otherwise it will cause electric shock.
- Do not remove the front cover of the servo driver while power is on, otherwise can cause an electric shock.
- Please wait at least 5 minutes after power has been removed before touching any terminal, otherwise the remaining high voltage possibly can cause an electric shock.
- Do not change the wiring while the power is on, otherwise can cause an electric shock.
- Do not disassemble the motor, otherwise can cause an electric shock.

6. Service range

 **Caution**

The products involved in this manual are for general industrial use. Do not use them on devices that may directly endanger personal safety, such as nuclear power devices, aerospace equipment, life support and maintenance equipment and various safety devices. If you need the above, please contact our company.

CONTENTS

Chapter 1 Product inspection and installation.....	1
1.1 Product inspection.....	1
1.2 Product nameplate.....	1
1.3 Product front panel.....	2
1.4 Servo driver installation.....	10
1.4.1 Installation environment conditions.....	10
1.4.2 Installation method.....	10
1.5 Servo motor installation.....	11
1.5.1 Installation environment conditions.....	11
1.5.2 Installation method.....	11
1.6 Motor rotation direction definition.....	12
Chapter 2 Wiring.....	13
2.1 System construction and wiring.....	13
2.1.1 Servo driver wiring diagram.....	13
2.1.2 Wiring instructions.....	18
2.1.3 Electric wire specifications.....	19
2.1.4 Main circuit terminal explanation.....	20
2.1.5 Motor and power wiring diagram.....	21
2.2 Brake resistance adaptation.....	25
2.3 Connection of reactor.....	26
2.4 X1 control signal terminal.....	27
2.4.1 X1 terminal plug.....	27
2.4.2 X1 terminal signal explanation.....	28
2.4.3 X1 terminal interface type.....	29
2.5 X2 encoder signal terminals.....	33
2.5.1 X2 terminal plug.....	33
2.5.2 X2 terminal signal description.....	33
2.6 X5、X6 terminals.....	34
2.6.1 X5、X6 terminals interface.....	34
2.6.2 X5、X6 terminals signal description.....	34
2.7 Standard wiring diagram.....	35
2.7.1 Position control wiring diagram.....	35
2.7.2 Speed control or torque control wiring diagram.....	36
Chapter 3 Front panel operation.....	37
3.1 Driver front panel description.....	37
3.1.1 Front panel compositions.....	37
3.1.2 Front panel explanations.....	37

3.1.3 Data display	38
3.2 Main menu	38
3.3 Status monitor	39
3.4 Parameters setting	43
3.5 Parameter management	44
3.6 Auxiliary functions	45
3.6.1 Special functions☆	45
3.6.2 Analog zeroing	46
3.7 Resume the parameter default values	47
Chapter 4 Running	48
4.1 Trial running with no load	48
4.1.1 Wiring and inspection	48
4.1.2 Trial running in JOG mode	48
4.2 Position control mode	49
4.2.1 Simple example of position control mode	49
4.2.2 Position command	50
4.2.3 Input electronic gear	53
4.2.4 Position control mode related gain	56
4.3 Speed control mode	57
4.3.1 Simple example of speed control mode	57
4.3.2 Parameters related to speed command	58
4.3.3 Speed command source	59
4.3.4 Acceleration and deceleration	60
4.3.5 Zero speed clamp	61
4.3.6 Speed control mode related gain	62
4.4 Torque control mode	63
4.4.1 Simple example of torque control mode	63
4.4.2 Parameters related to torque command	64
4.4.3 Torque command source	64
4.4.4 Speed limit in torque control mode	65
4.5 Gain adjustment	66
4.5.1 Gain parameters	67
4.5.2 Gain adjustment steps	68
4.6 Resonance suppressions	69
4.6.1 Low pass filters	71
4.6.2 Notch filters	71
4.7 Gains switching	72
4.7.1 Gain switching parameters	72
4.7.2 Gain switching action	73
4.8 Homing	74

4.8.1 Homing parameters	74
4.8.2 Homing operation steps	74
4.8.3 Homing timing chart	75
4.8.4 Homing combination mode timing chart	77
4.9 Absolute value encoder setting☆	82
4.9.1 Absolute value encoder multi turn information backup☆	82
4.9.2 Initialization of the absolute encoder☆	82
4.10 Over-travel protection	83
4.11 Torque limit	84
4.11.1 Torque limit parameters	84
4.11.2 Torque limit mode	84
4.12 Timing chart of operation.....	85
4.12.1 Timing chart when power supply switch on	85
4.12.2 Alarm timing chart while servo-ON is executed.....	86
4.12.3 Servo ON/OFF action timing when the motor is stationary	87
4.12.4 Servo ON/OFF action timing when the motor is running.....	87
4.13 Electromagnetic brake.....	88
4.13.1 Electromagnetic brake parameter.....	88
4.13.2 Use of electromagnetic brake.....	88
Chapter 5 Parameters	90
5.1 Parameter description in detail.....	90
5.1.1 Parameters of section 0	90
5.1.2 Parameters of section 1	109
5.1.3 Parameters of section 2	119
5.1.4 Parameters of section 3	124
5.2 DI function details.....	126
5.3 DO function details	130
Chapter 6 Communication functions	131
6.1 Communication hardware interface.....	131
6.2 Communication parameter	131
6.3 MODBUS communication protocol	131
6.4 Write in and read out parameters	137
6.5 Common operation commands	137
6.6 State quantity monitoring.....	138
Chapter 7 Alarm	140
7.1 Alarm causes and handling.....	140
Chapter 8 Specifications	148
8.1 Driver model	148
8.2 Driver size	149
8.3 Driver specifications	151

8.4 Motor adaptation table of the driver	152
8.5 Servo motor model.....	154
8.6 Servo motor wiring	154
8.6.1 Winding wiring	154
8.6.2 Brake wiring.....	155
8.6.3 Encoder	156

Chapter 1 Product inspection and installation

1.1 Product inspection

This product has undergone a complete functional test before delivery. In order to prevent the product from being abnormal due to negligence during the delivery process, please inspect the following items in detail after unpacking:

- Inspect whether the models of the servo driver and servo motor are the same as those ordered.
- Inspect whether the appearance of the servo driver and servo motor is damaged or scratched. When damage is caused during transportation, please do not connect wires for power transmission.
- Inspect whether the servo driver and servo motor are loose. Whether there are loose screws, whether the screws are not locked or fall off.
- Inspect whether the rotor shaft of the servo motor can rotate smoothly by hand. The motor with brake cannot rotate directly.

If the above items have faults or abnormal phenomena, please contact the dealer immediately.

1.2 Product nameplate

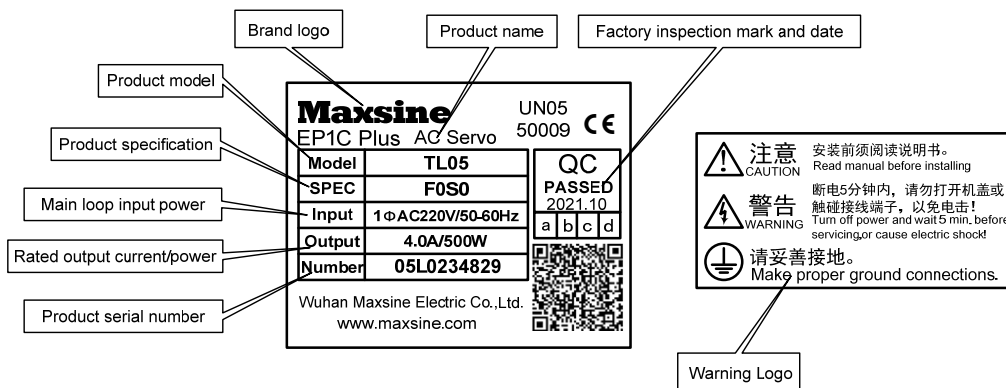

1.3 Product front panel

Applicable models: TL01、TL02、TL05、TL08、TL10、TL15

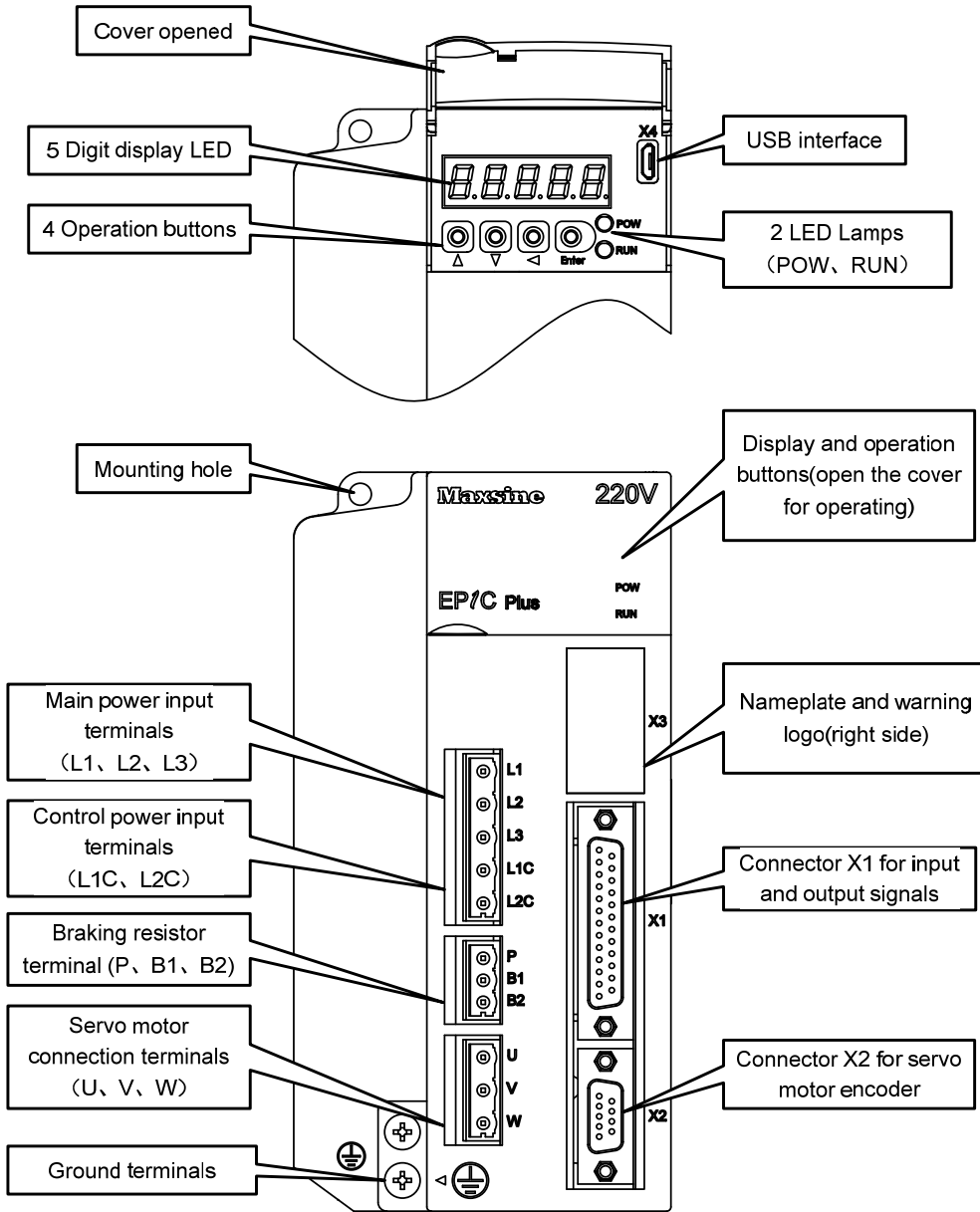

Applicable models: TL25

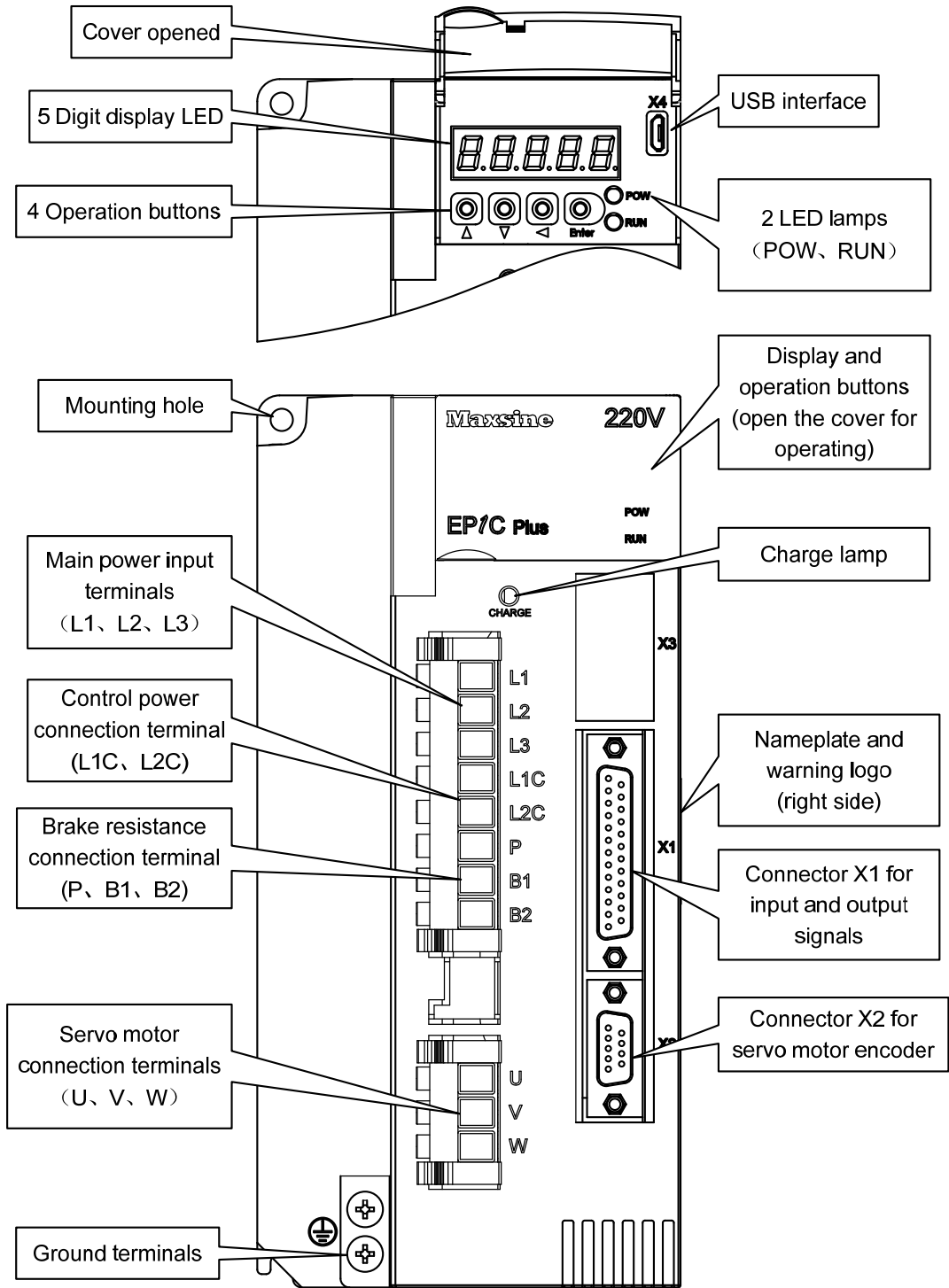

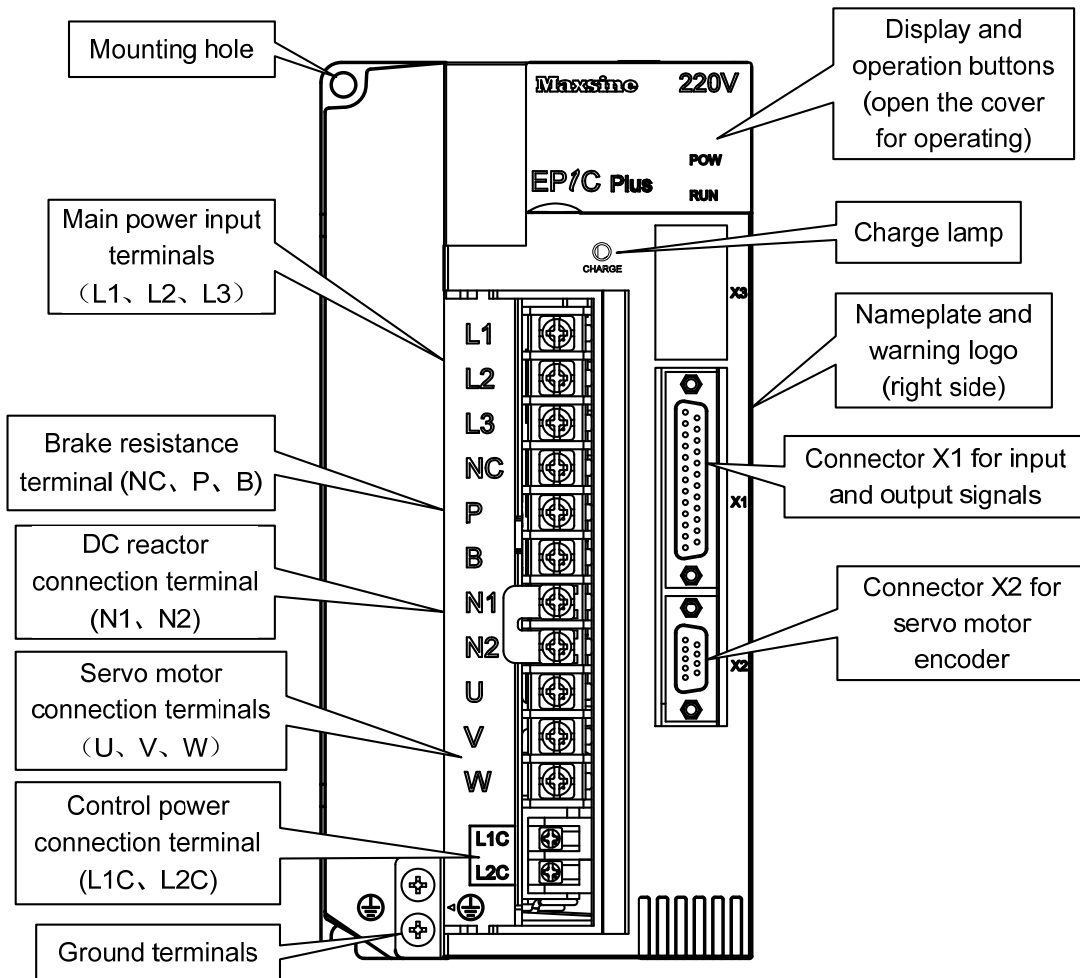
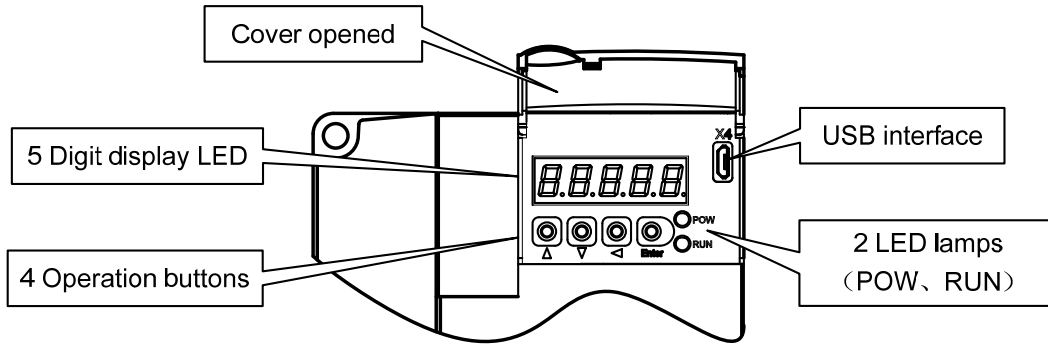

Applicable models: TH06、TH10、TH15

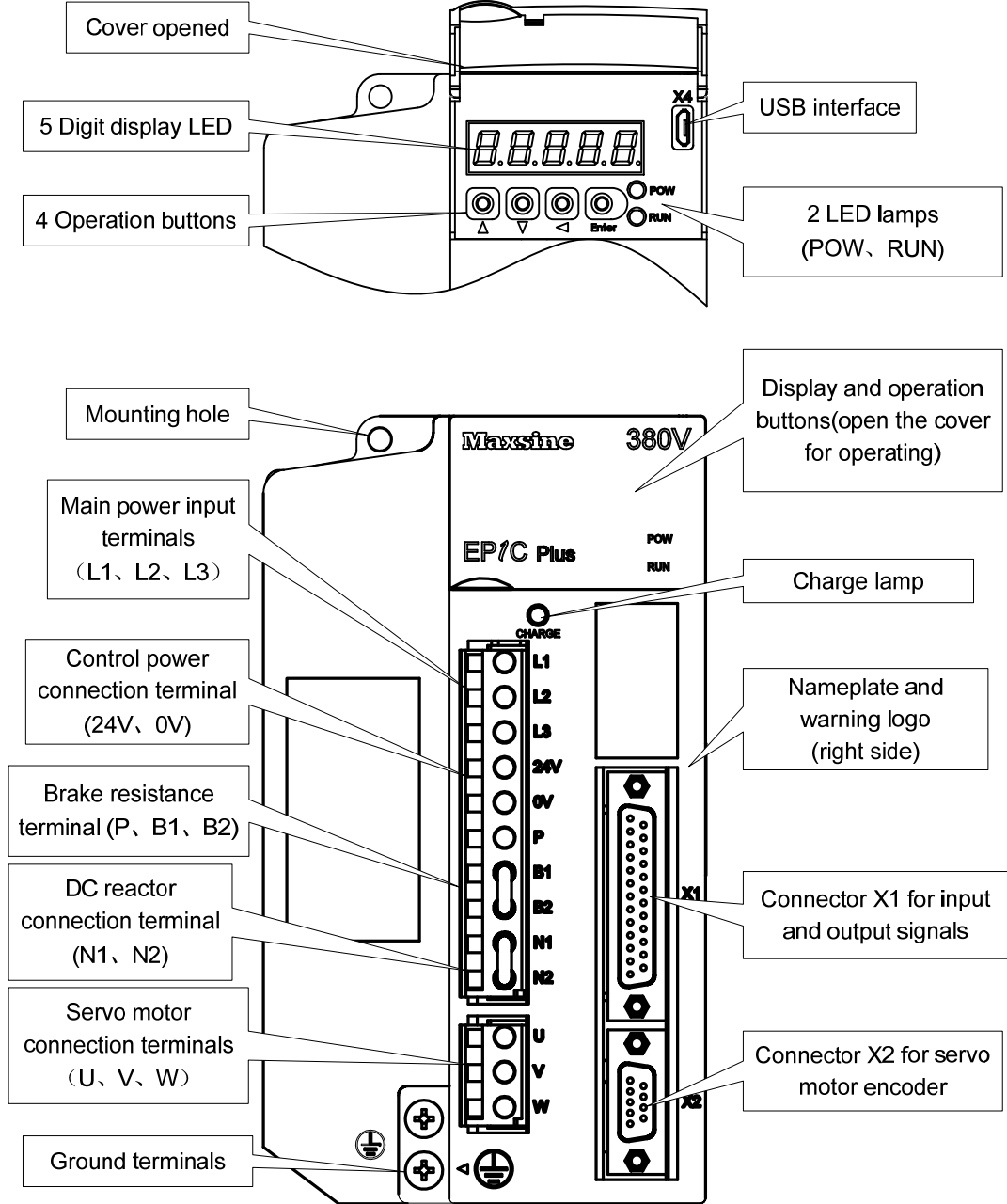

Applicable models: TH20

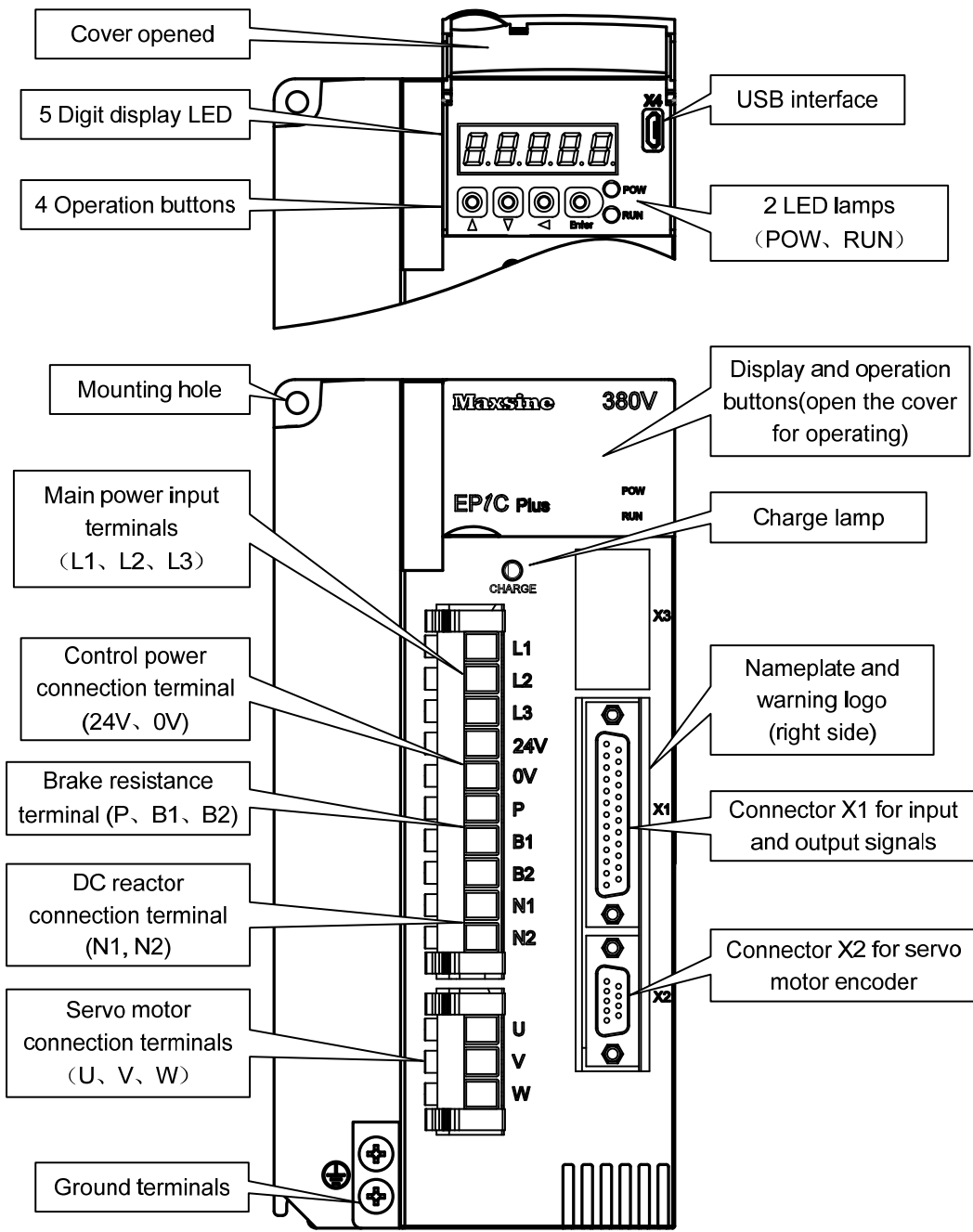

Applicable models: TH30、TH50、TH75

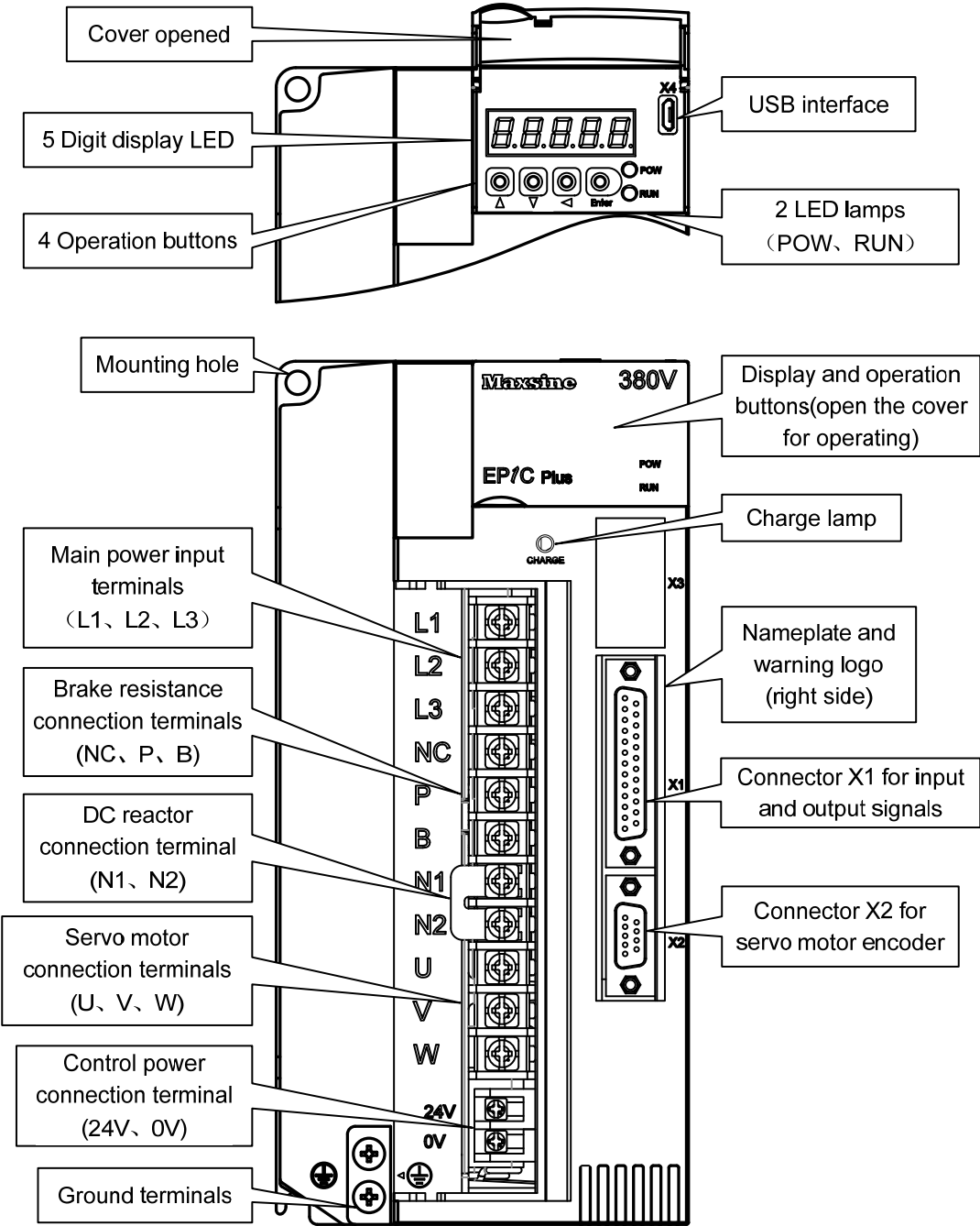

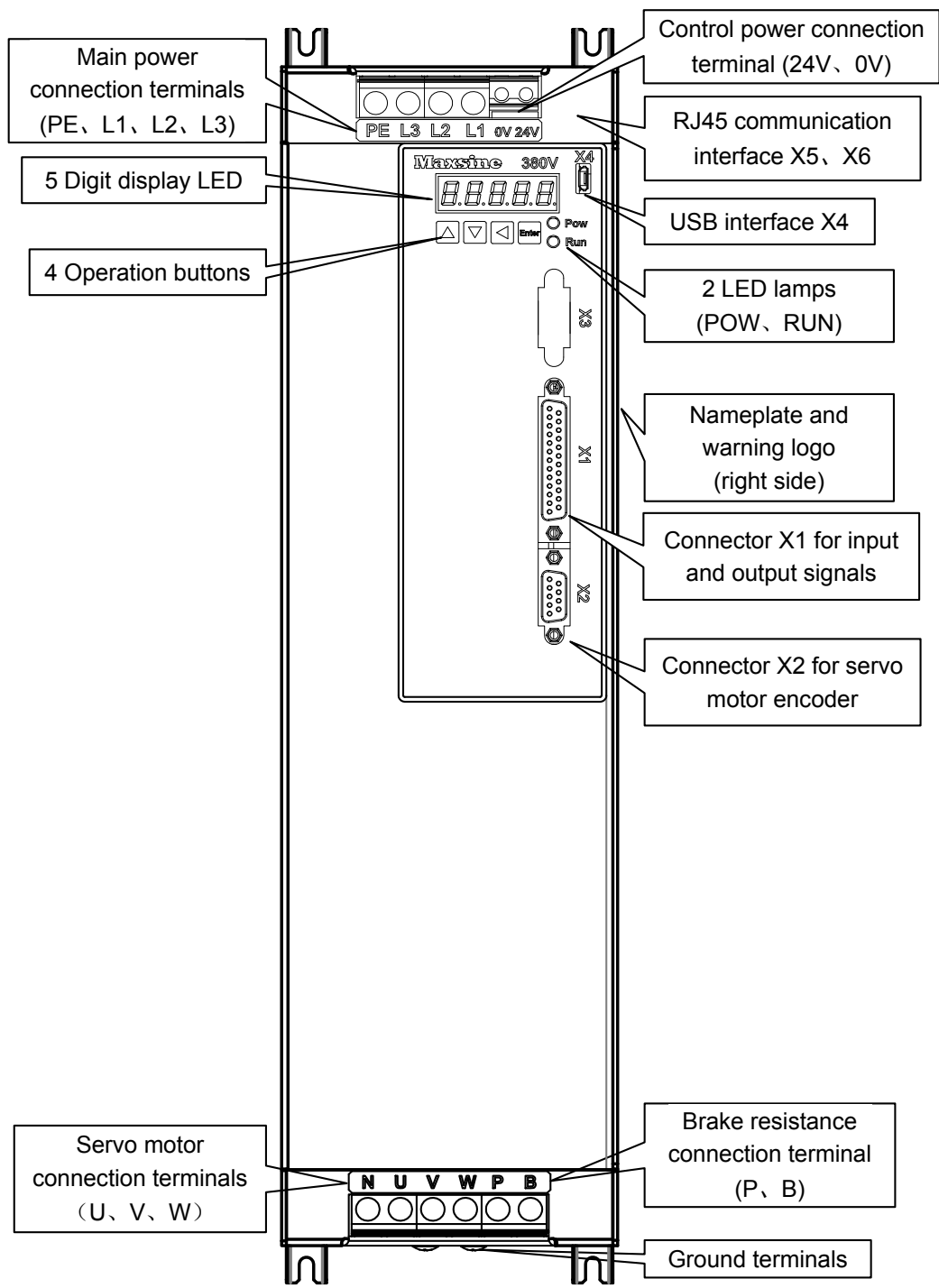

Applicable models: TH110、TH150

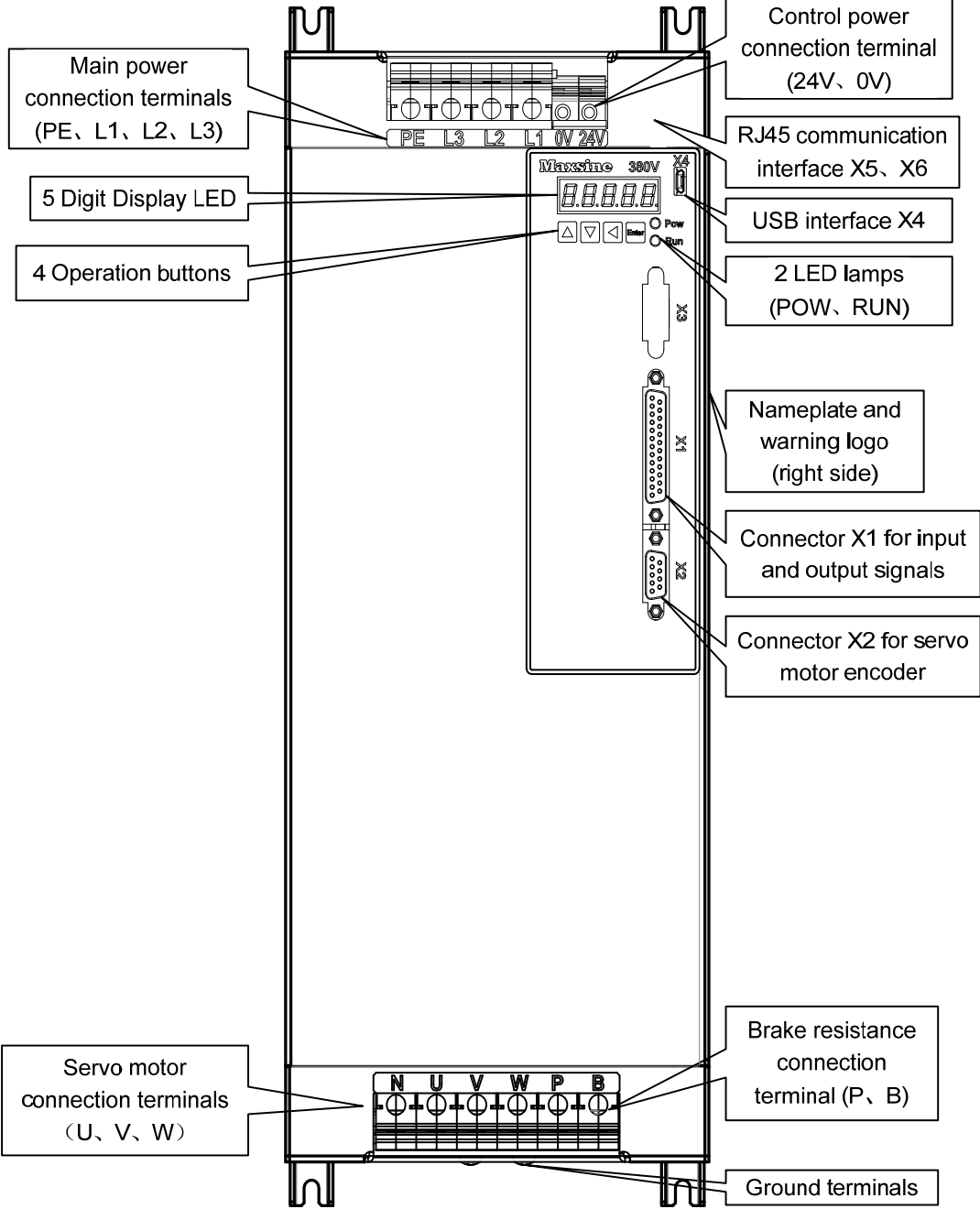

1.4 Servo driver installation

1.4.1 Installation environment conditions

The installation environment of the servo driver has a direct impact on the normal function and service life of the driver, so the installation environment of the driver must meet the following conditions:

- Ambient temperature: 0~40°C; Ambient humidity: below 40%~80% (no dew).
- Storage temperature: -40~50°C; Storage humidity: below 93% (no dew).
- Vibration: below 0.5G.
- Prevent rain dripping or humid environment.
- Avoid direct sunlight.
- Prevent oil mist and salt erosion.
- Prevent corrosive liquid and gas erosion.
- Prevent dust, cotton wadding and metal debris from invading.
- Keep away from radioactive substances and combustibles.
- When several drives are installed in the control cabinet, please note that enough space should be reserved in the placement position to facilitate air flow and heat dissipation. Please add a cooling fan to reduce the temperature around the servo drive. The long-term safe working temperature is below 40°C.
- When there is a vibration source nearby (such as a punch press), if it is unavoidable, please use a vibration absorber or install anti vibration rubber gaskets.
- When there is interference equipment nearby, there is interference to the power line and control line of the servo driver, which may cause the driver to malfunction. Noise filter and other anti-interference measures can be added to ensure the normal operation of the driver. However, the noise filter will increase the leakage current, so it is necessary to install an isolation transformer on the power input end of the driver.

1.4.2 Installation method

- The normal installation direction of servo driver is vertical and upright, with the top facing up to facilitate heat dissipation.
- During installation, tighten the M5 fixing screws at the rear of the servo driver.
- The installation intervals between servo drives and other equipment are shown in the figure. In order to ensure the service performance and service life of the drive, please leave sufficient installation intervals as far as possible.
- A cooling fan must be installed in the electrical control cabinet to ensure that the vertical wind dissipates heat to the radiator of the servo drive.
- When installing the electrical control cabinet, prevent dust or iron filings from entering the servo driver.

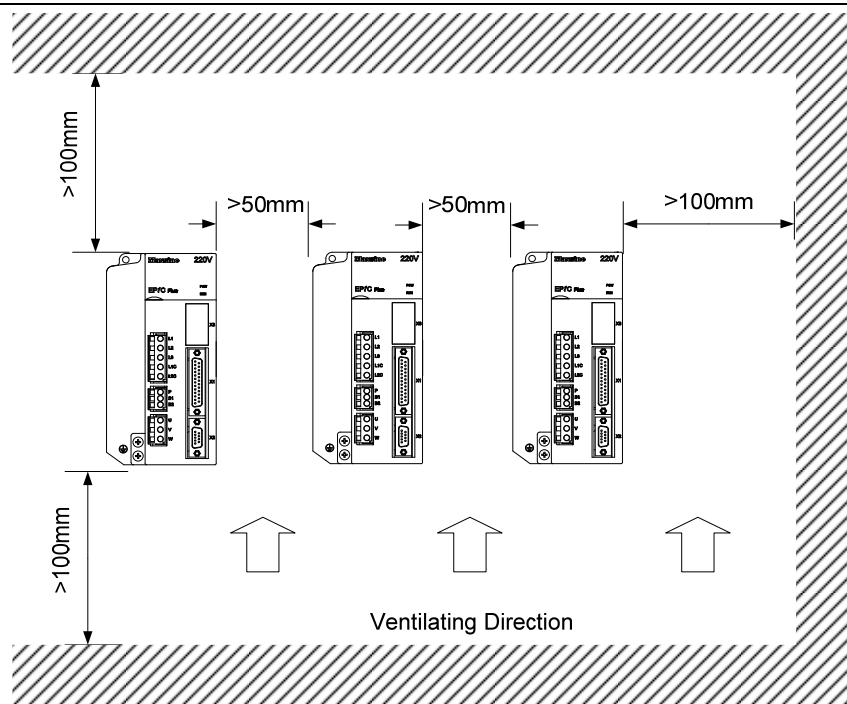

1.5 Servo motor installation

1.5.1 Installation environment conditions

- Ambient temperature: 0~40°C; Ambient humidity: below 80 % (no dew).
- Storage temperature: -40~50°C; Storage humidity: below 80 % (no dew).
- Vibration: below 0.5G.
- Places with good ventilation and less moisture and dust.
- No corrosive, igniting gas, oil and gas, cutting fluid, cutting powder, iron powder and other environments.
- Places without water vapor and direct sunlight.

1.5.2 Installation method

- Horizontal installation: to prevent water, oil and other liquids from flowing into the motor from the outlet end of the motor, please place the cable outlet below.
- Vertical installation: if the motor shaft is installed upward and the reducer is attached, pay attention to and prevent oil stains in the reducer from penetrating into the motor through the motor shaft.
- The extension of the motor shaft should be sufficient. If the extension is insufficient, it will easily cause vibration when the motor moves.
- When installing and disassembling the motor, do not knock the motor with a hammer, otherwise it is easy to cause damage to the motor shaft and encoder.

1.6 Motor rotation direction definition

The definition of rotation direction of the motor described in this manual: facing the motor shaft extension, counterclockwise rotation of the rotating shaft (CCW) is positive rotation, and clockwise rotation of the rotating shaft (CW) is reverse rotation.

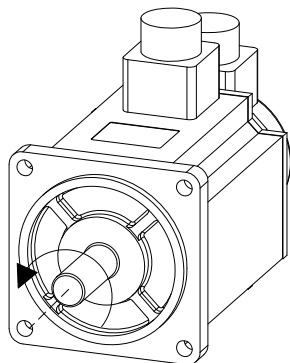

Positive Rotation
(CCW)

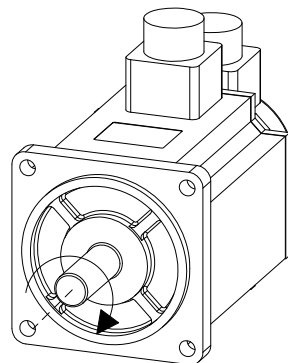

Reversal Rotation
(CW)

Chapter 2 Wiring

2.1 System construction and wiring

2.1.1 Servo driver wiring diagram

1. EP1C Plus-TL series servo driver wiring diagram

Applicable models: TL01、TL02、TL05

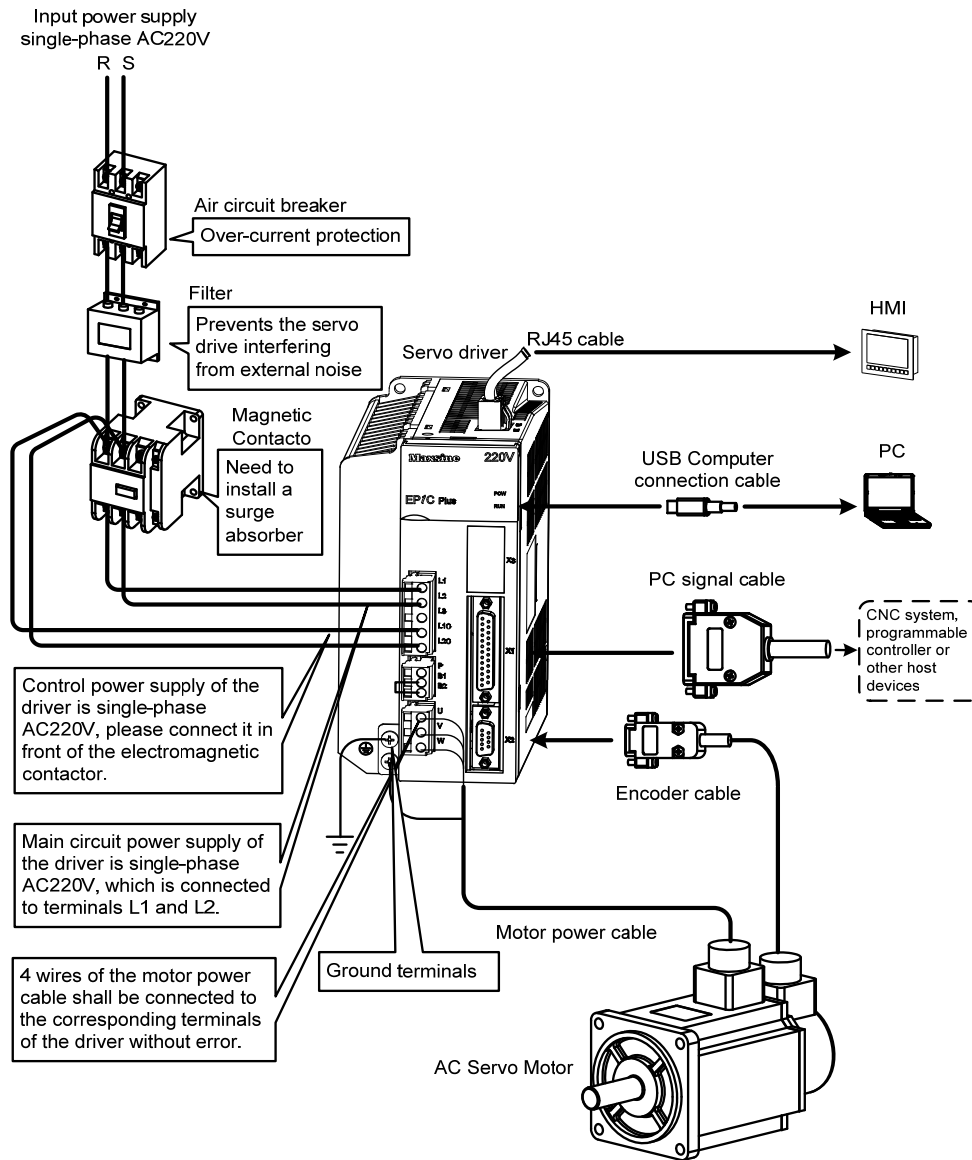

Applicable models: TL08、TL10、TL15、TL25

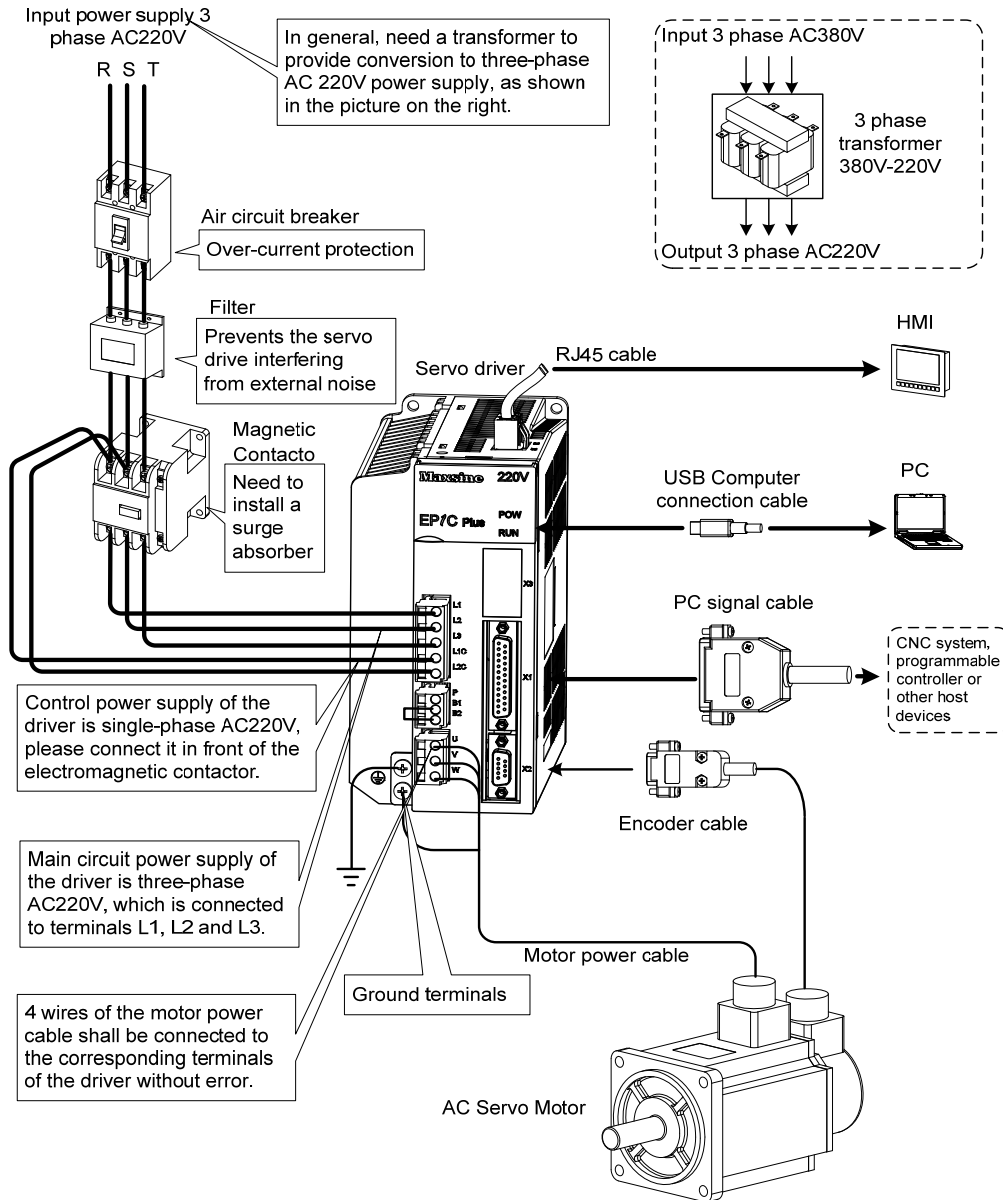

Note: please refer to section 2.1.5 for details of TL35 and TL55.

2. EP1C Plus-TH series servo driver wiring diagram

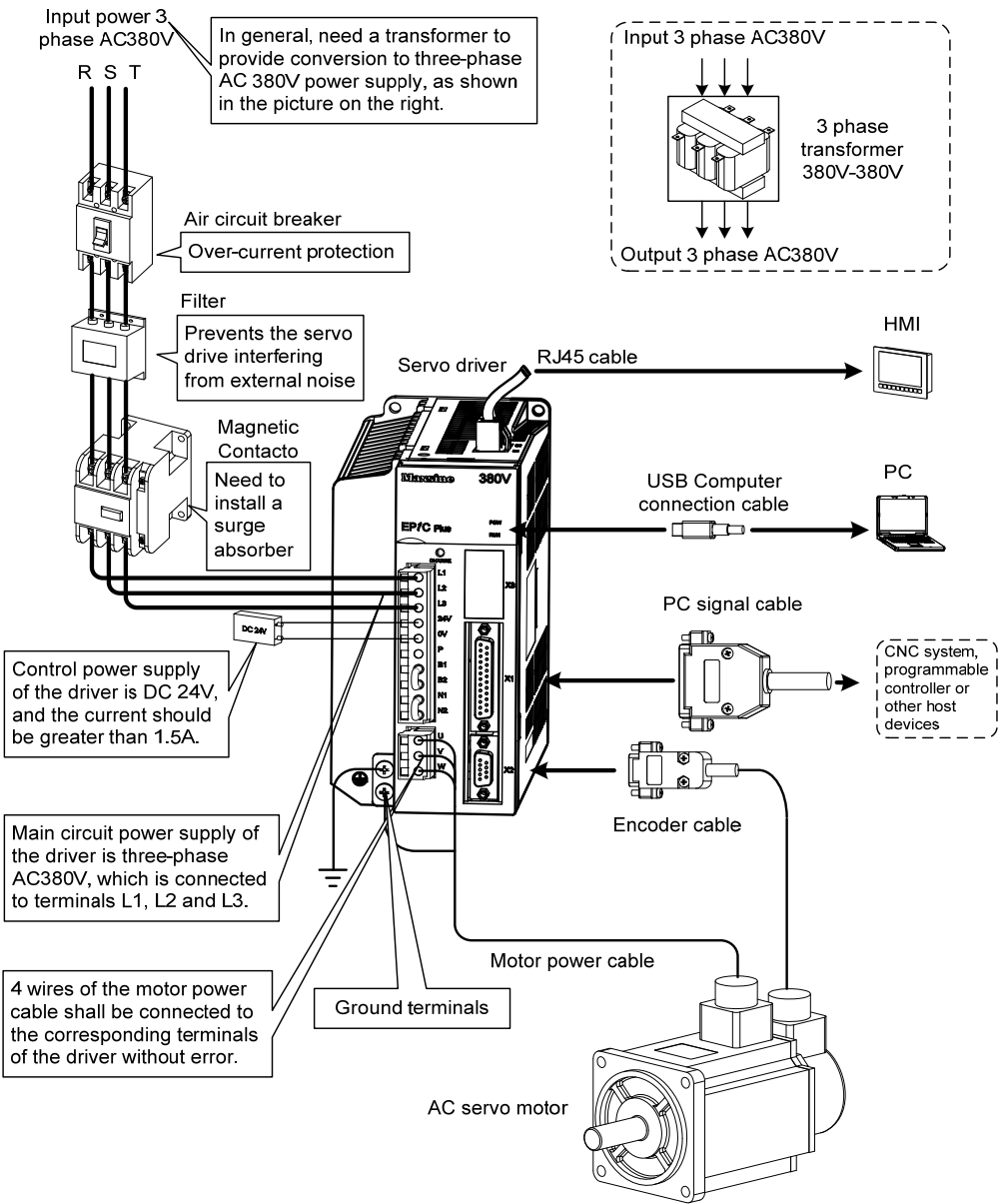

Note: This wiring method only applies to TH06、 TH10 and TH15, and please refer to section 2.1.5 for details of TH20、 TH30、 TH50 and TH75.

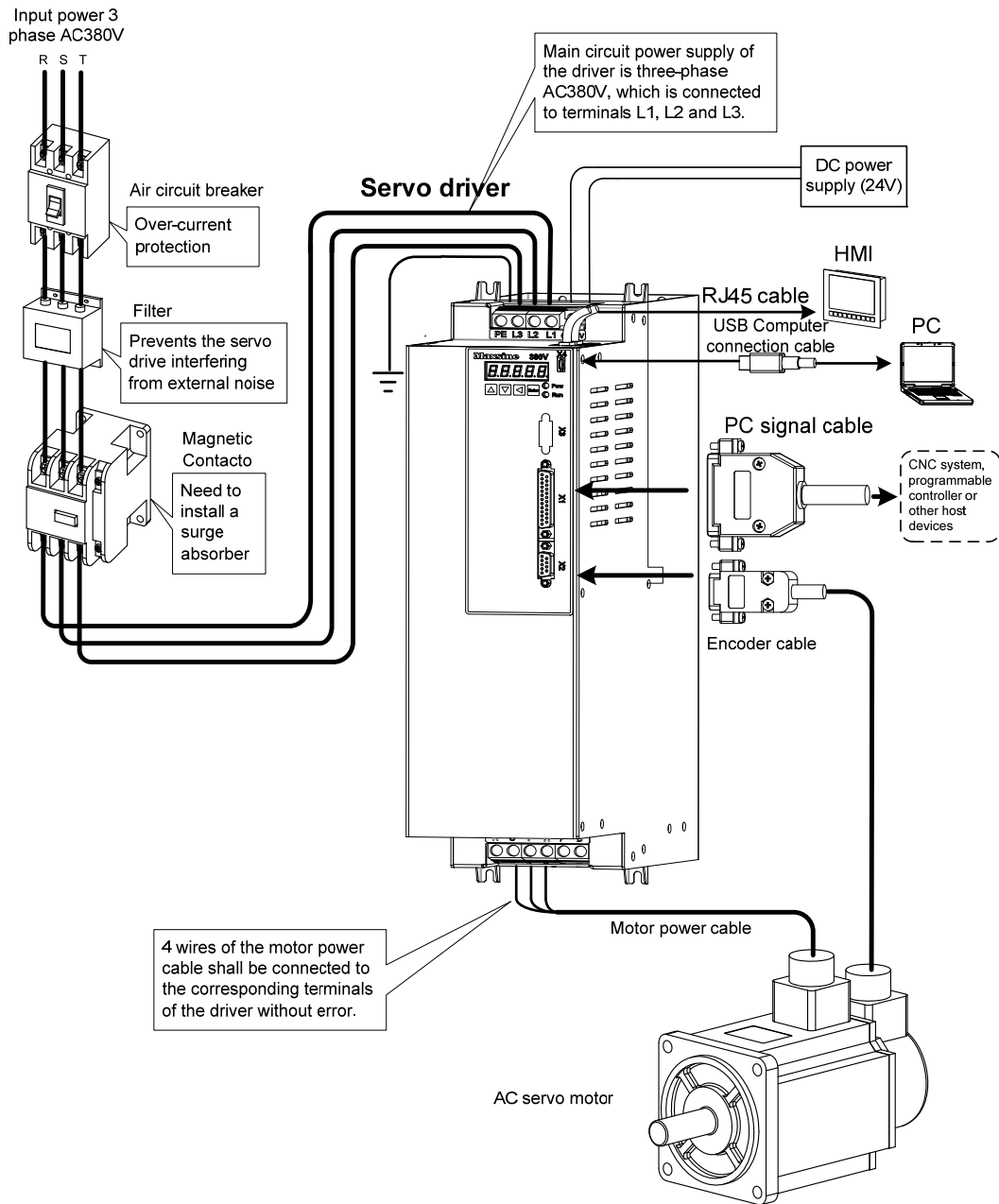

Applicable models: TH110、TH150

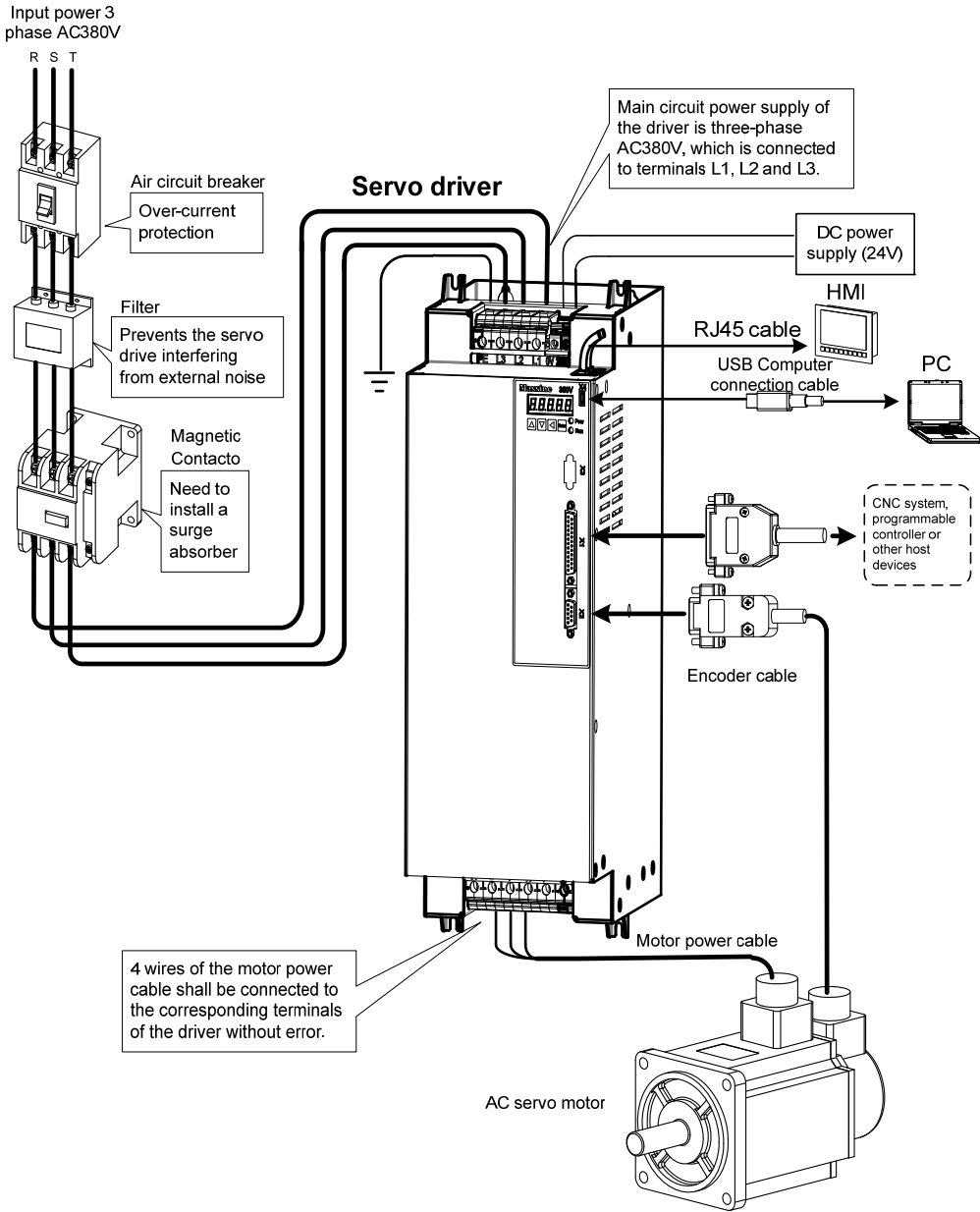

2.1.2 Wiring instructions

Wiring notice:



- Wiring materials shall be used according to wire specifications.
- Cable length, command cable within 3m, encoder cable within 20m.
- Check whether the power supply and wiring of L1, L2, L3, L1C and L2C are correct. Do not connect to the 380V power supply.
- The output terminals(U、 V、 W) must be connected with the servo motor connections(U、 V、 W) correspondently, otherwise the servo motor will stop or over speed. However, by exchanging three-phase terminal cannot cause the motor to reverse; this point is different from an asynchronous motor.
- It must be reliably grounded and grounded at a single point.
- For the relay installed in the output signal, the diode for absorption shall be connected in the correct direction, otherwise it will cause failure and fail to output the signal.
- In order to prevent wrong action caused by noise, please add insulation transformer, noise filter and other devices to the power supply.
- Please wire the power line (power supply line, main circuit lines, etc.) more than 30cm away from the signal line, and do not place it in the same wiring pipe.
- Please install non fusible circuit breaker to cut off external power supply in time when the driver fails.

2.1.3 Electric wire specifications

Connect terminal	Symbol	Wire specification	
Main power supply	L1、L2、L3	100W~1.5kW	0.75~1.5mm ²
		1.5kW~3.5kW	1.5~2.5mm ²
		3.5kW~5.5kW	2.5~4mm ²
		5.5kW~7.5kW	2.5~4mm ²
		7.5kW~11kW	6~10mm ²
		11kW~15kW	10mm ²
Control power supply	L1C、L2C	0.75~1.0mm ²	
	24V、0V	0.75~1.0mm ²	
Servo motor connection terminal	U、V、W	100W~1.5kW	0.75~1.5mm ²
		1.5kW~3.5kW	1.5~2.5mm ²
		3.5kW~5.5kW	2.5~4mm ²
		7.5kW~11kW	6~10mm ²
		11kW~15kW	10mm ²
Ground terminal	⊕	1.5~4mm ²	
Control signals	X1	≥0.14mm ² (AWG26),shielded	
Encoder signals	X2	≥0.14mm ² (AWG26),shielded	
USB communication	X4	≥0.14mm ² (AWG26)	
RJ45 communication	X5、X6	≥0.14mm ² (AWG26)	
Brake resistor Terminal	P、B、B1、B2	1.5~4mm ²	

Must use a twisted pair wire cable for the encoder signal wiring. If the encoder signal cable is too long (>20m), in which the encoder power supply can be insufficient, may use multi-wire or thick wire for the power supply wiring.

2.1.4 Main circuit terminal explanation

Name	Terminal symbol	model	Detailed instructions
Main power supply	L1、L2	TL01、TL02、TL05	Connect external AC power supply: single-phase 220VAC - 15% ~ + 10% 50/60 Hz
	L1、L2、L3	TL08、TL10、TL15 TL25、TL35、TL55	Connect external AC power supply: three-phase 220VAC -15%~+10% 50/60Hz
	L1、L2、L3	TH series	Connect external AC power supply: three-phase 380VAC - 15% ~ + 10% 50/60 Hz
Control power supply	L1C、L2C	TL series	Connect external AC power supply: single-phase 220VAC -15%~+10% 50/60 Hz
	24V、0V	TH series	External DC24V
Brake resistor terminal	P、B1、B2	TL01、TL02、TL05 TL08、TL10、TL15 TL25、TH06、TH10 TH15	When the external braking resistance is needed, disconnect B1、B2[Note 2], and the external braking resistance is connected to the P and B1 ends to make B2 suspended.
	NC、P、B	TL35、TL55[Note 1] TH20、TH30、TH50 TH75、TH90、TH110 TH150	When using external braking resistor, must first be open between P and B in braking resistance line, at the same time the two braking resistor inside thread on NC, then the external braking resistor jumper on the P、B.
DC reactor connection terminal for high harmonic suppression of power supply	N1 N2	TL35、TL55、TH series	DC reactor is connected between N1 and N2 [Note 2] when high-order harmonics of power supply need to be suppressed.
Motor connection terminal	U	EP1C Plus series	Output to motor U phase power supply
	V		Output to motor V phase power supply
	W		Output to the motor W phase power supply
Ground terminal		EP1C Plus series	Grounding terminal of motor housing
			Driver grounding terminal

Note 1. TL01、TL55、TH50、TH75、TH90、TH110、TH150 do not have internal brake resistors. TL01 generally does not need to be connected to brake resistors, but TL55、TH50、TH75、TH90、TH110、TH150 need to be connected to external brake resistors. The external brake resistance should be connected across the P and B ends, and the NC is suspended.

Note 2. Except TL01、TL55、TH50、TH75, internal brake resistance is connected by default at the factory. B1 and B2 are short-connected, N1 and N2 are short-connected. It is recommended to configure dynamic resistors for TL55、TH50、TH75、TH90、TH110、TH150 drivers.

2.1.5 Motor and power wiring diagram

1. TL series servo driver power supply adopts three-phase AC220V, generally obtained from three-phase AC380V through transformer. In special cases, motors less than 750W can use single-phase 220V (single-phase power is connected to L1 and L2, leaving L3 suspended).

Applicable models: TL01 [Note]

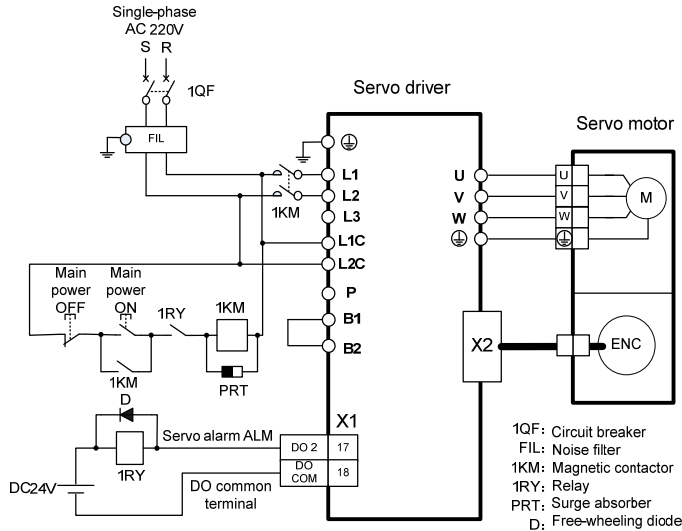

Note: TL01 has no internal brake resistance and generally does not need to be connected to the brake resistance.

Applicable models: TL02、TL05

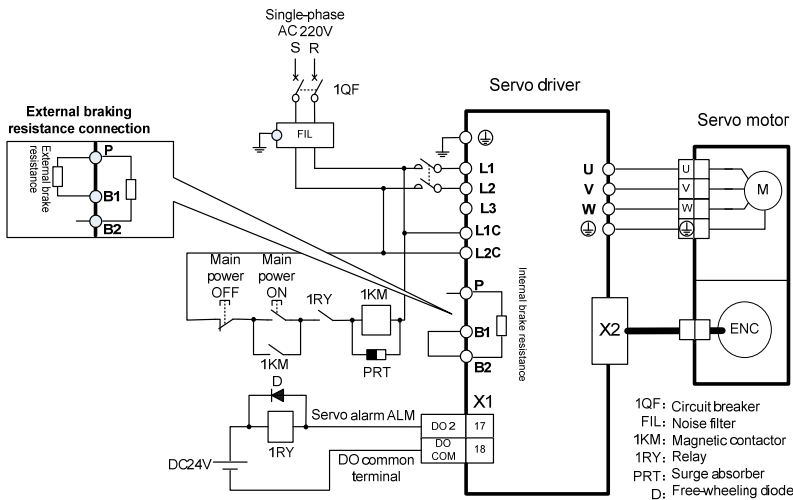

Applicable models: TL08、TL10、TL15、TL25

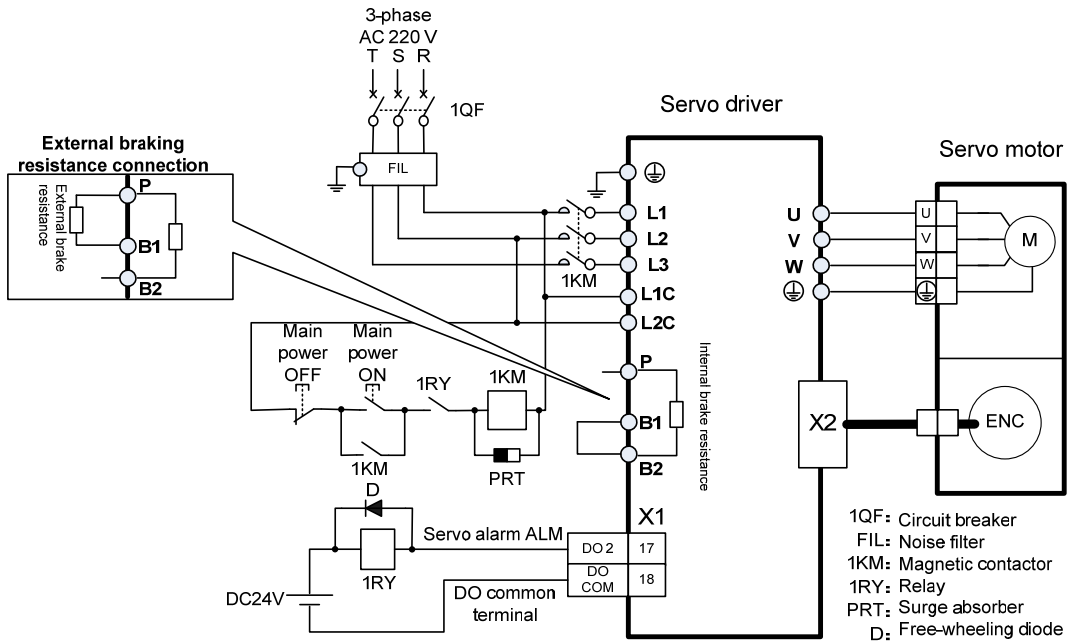

Applicable models: TL35

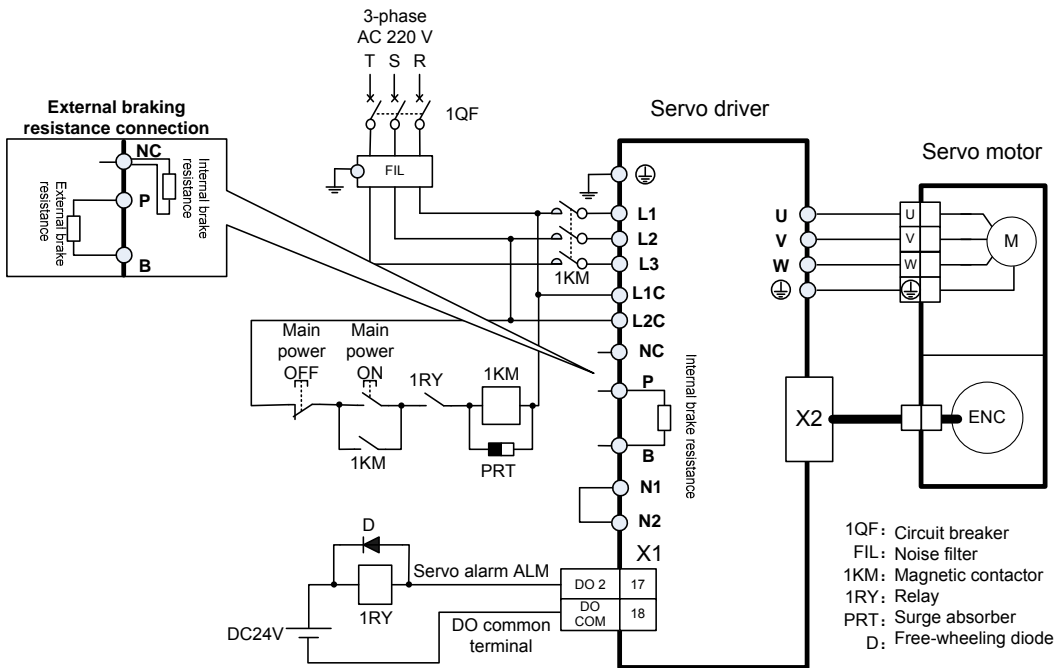

Applicable models: TL55 [Note]

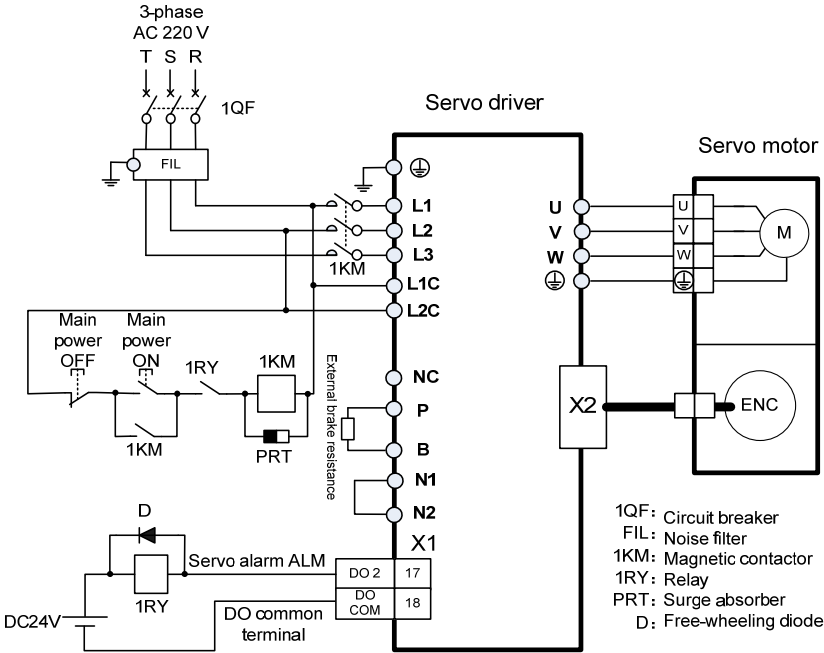

Note: TL55 has no internal brake resistance and needs to be connected to external brake resistance for use.

2. TH series two different wiring modes:

Applicable models: TH06、TH10、TH15、TH20

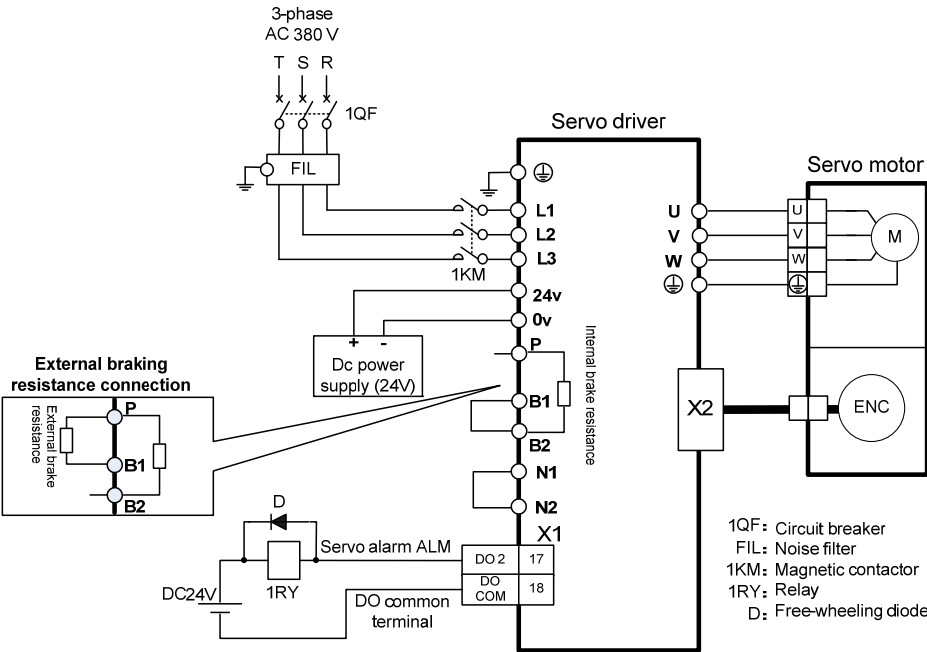

Applicable models: TH30

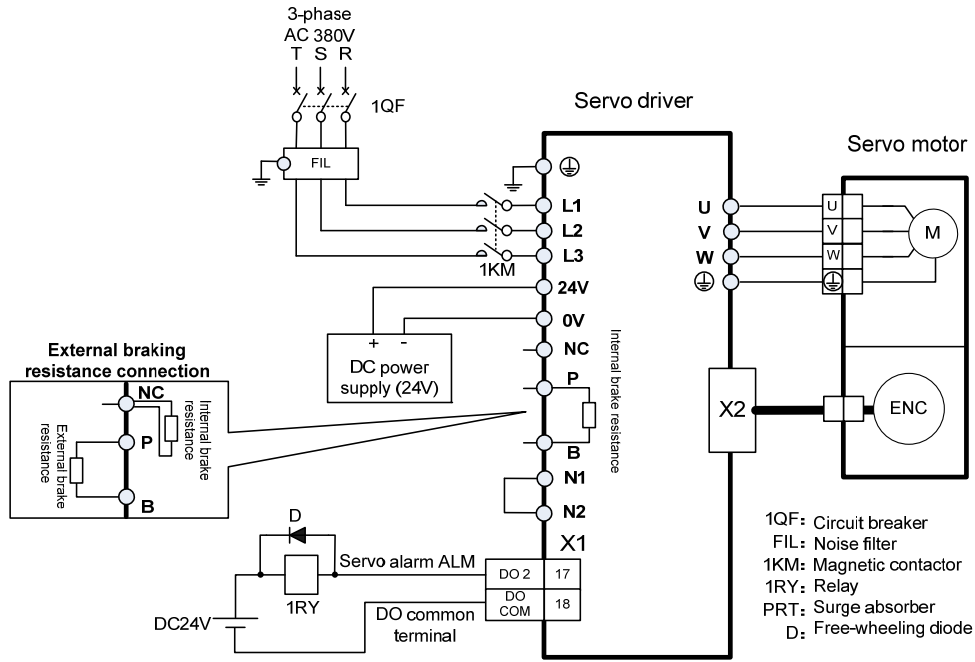

Applicable models: TH50、TH75、TH90、TH110、TH150 [Note]

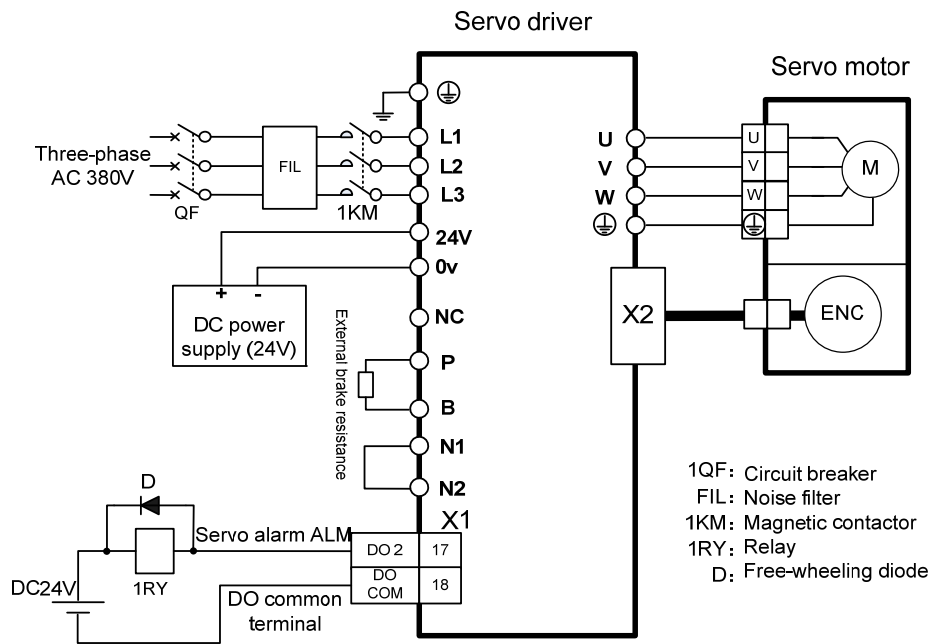

Note: TH50、TH75、TH90、TH110、TH150 without internal brake resistance, need to connect the external braking resistor is used.

2.2 Brake resistance adaptation

Drive series		Internal brake resistance specification	Recommended specification of external brake resistance	Minimum external brake resistance
AC220V	TL01	None	47 Ω /100W	30 Ω
	TL02	47 Ω /100W	36 Ω /200W	30 Ω
	TL05	47 Ω /100W	36 Ω /200W	30 Ω
	TL08	47 Ω /100W	36 Ω /200W	25 Ω
	TL10	47 Ω /100W	36 Ω /200W	25 Ω
	TL15	47 Ω /100W	25 Ω /200W	20 Ω
	TL25	47 Ω /100W	25 Ω /200W	20 Ω
	TL35	47 Ω /100W	20 Ω /500W	12 Ω
	TL55	None	20 Ω /500W	12 Ω
AC380V	TH06	117 Ω /100W	50 Ω /500W	45 Ω
	TH10	117 Ω /100W	50 Ω /500W	45 Ω
	TH15	117 Ω /100W	50 Ω /500W	45 Ω
	TH20	47 Ω /100W	50 Ω /500W	40 Ω
	TH30	47 Ω /100W	36 Ω /750W	30 Ω
	TH50	None	36 Ω /750W	30 Ω
	TH75	None	20 Ω /1000W	15 Ω
	TH90	None	20 Ω /1000W	15 Ω
	TH110	None	20 Ω /1000W	15 Ω
	TH150	None	20 Ω /1000W	12 Ω

Note 1: The resistances recommended in the table can be used in most applications. In practical application, if the demand cannot be met, please contact the manufacturer.

Note 2: When all drivers are changed to external brake resistance, parameters P084/P085/P086 should be modified accordingly. Refer to the corresponding parameter description in chapter 5.1.1 for specific modification.

2.3 Connection of reactor

When it is necessary to suppress the high-order harmonics of the power supply, connect the dc reactor between N1 and N2.

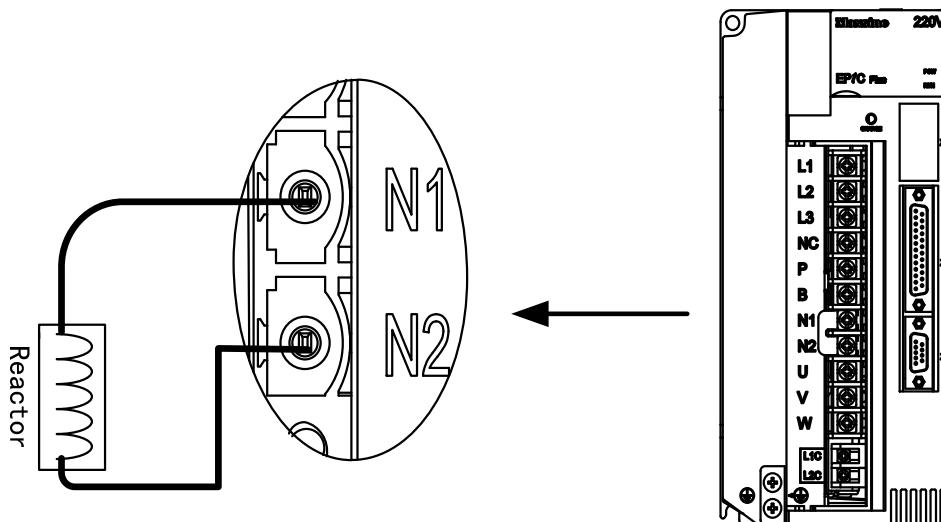

Note: Only TL35、TL55 and TH complete series (except TH90、TH110、TH150) servo drivers have external reactor connection function.

2.4 X1 control signal terminal

X1 control signal terminals for connected to the host controller signals, use DB25 socket, signs include:

- 5 programmable inputs;
- 3 programmable outputs;
- Analog command input;
- Command pulse input;
- Encoder signal output.

2.4.1 X1 terminal plug

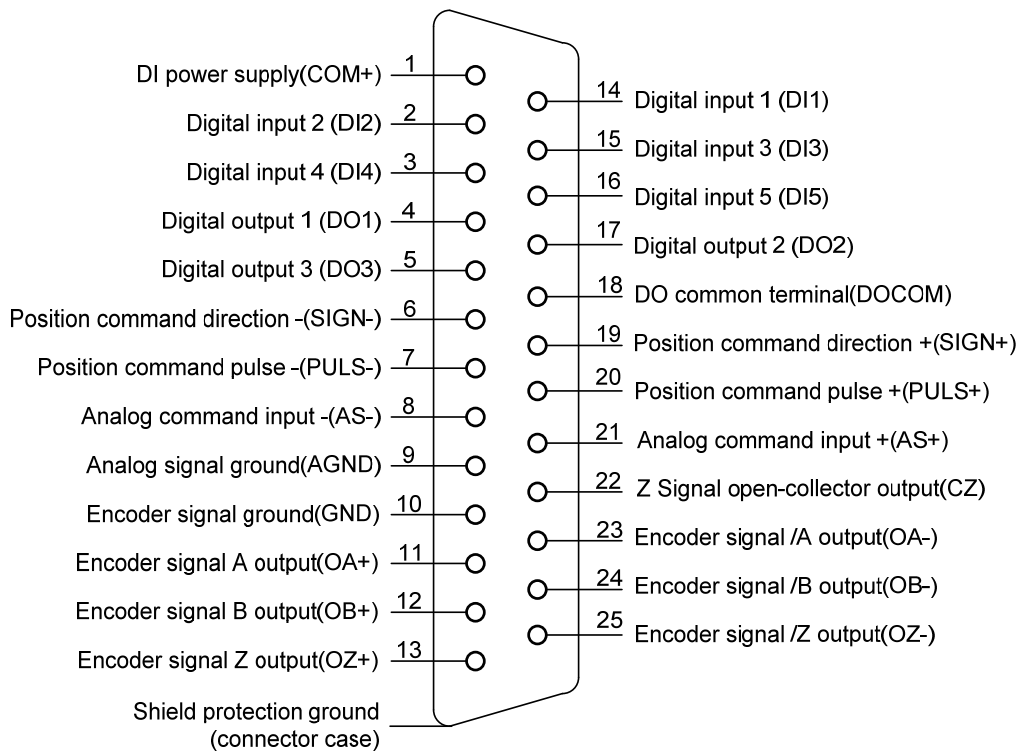

Driver X1 plug

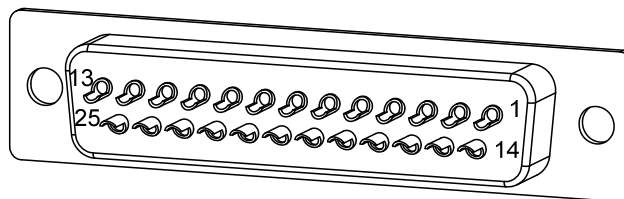

X1 plug welding pin distribution

2.4.2 X1 terminal signal explanation

Signal name		Pin number	Functions	Interface
Digital input	DI1	14	Photoelectric isolation input, programmable function, defined by parameters P100~P104.	C1
	DI2	2		
	DI3	15		
	DI4	3		
	DI5	16		
	COM+	1	DI power supply (DC12V ~ 24V)	
Digital output	DO1	4	Photoelectric isolation and output, the maximum output capacity 50mA/25V, programmable function, defined by the parameter P130~P132.	C2
	DO2	17		
	DO3	5		
	DOCOM	18	DO common terminal	
Position command pulse	PULS+	20	High speed photo isolation input; Working mode set by parameter P035:	C3
	PULS-	7		
	SIGN+	19	<ul style="list-style-type: none"> ● Pulse + direction; ● Positive/Reverse pulse; ● Orthogonal pulse. 	
	SIGN-	6		
Analog command inputs	AS+	21	Speed/torque analog input; the range is -10V~+10V.	C4
	AS-	8		
	AGND	9	Analog signal Ground.	
Output signals of encoder	OA+	11	Differential driver(Line Driver) output after frequency division of encoder signal	C5
	OA-	23		
	OB+	12		
	OB-	24		
	OZ+	13		
	OZ-	25		
	CZ	22	Open collector output of Z signal.	C6
	GND	10	Encoder signal ground.	
Shielded cable ground protection	Metal case of connector		Shielded wire connecting shielded cable	

2.4.3 X1 terminal interface type

The following will introduce the interface circuits of X1 and the wiring mode with the host control device.

1. Digital input interfaces (C1)

Digital input interface circuit can be controlled by switches, relays, open collector triodes, photoelectric coupler, etc. Low current relay shall be selected for the relay to avoid poor contact. External voltage range is DC12V~24V.

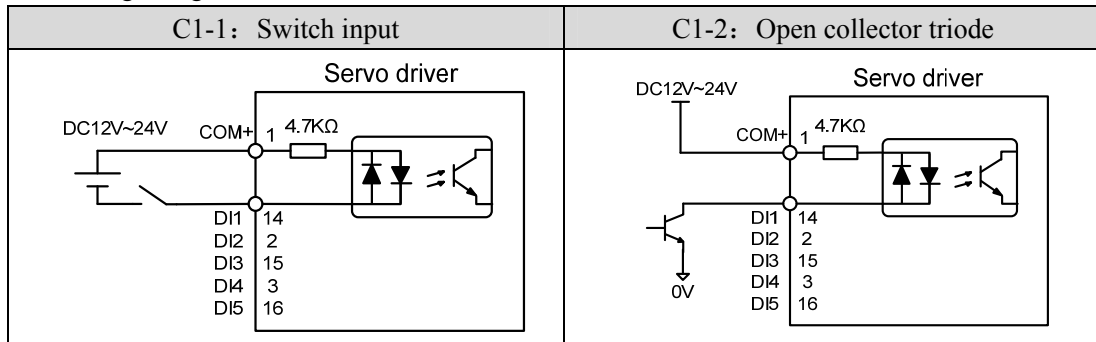

2. Digital output interfaces (C2)

The output circuit adopts Darlington photoelectric coupler, which can be connected with relay and photoelectric coupler. Precautions:

- The power supply is provided by the user. If the power supply is reversed, the drive will be damaged.
- The maximum external power supply is 25V, the maximum output current is 50mA, and the sum of the three currents does not exceed 100mA.
- When using inductive loads such as relays, add diodes in parallel with inductive loads. If the polarity of diodes is opposite, the driver will be damaged.
- When conducting, there is a voltage drop of about 1V, which cannot meet the low level requirements of TTL, so it cannot be directly connected to the TTL circuit.

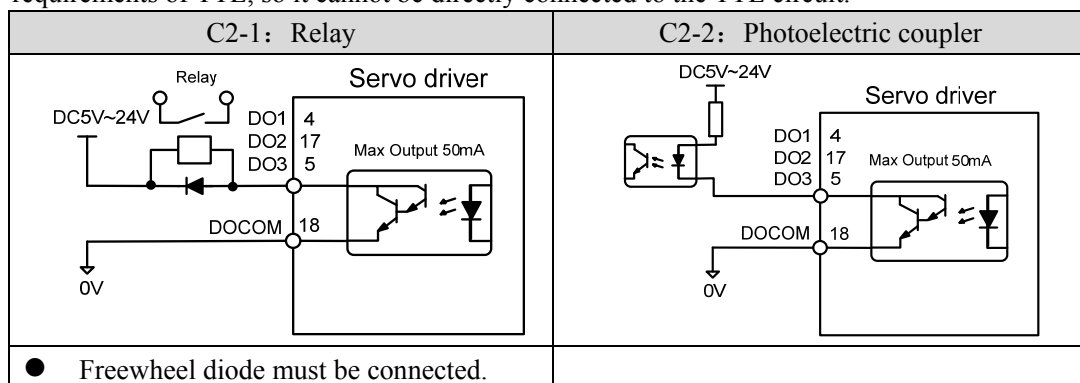

3. Position command pulse interfaces (C3)

There are 3 kinds of connections: differential drive, common single end and 24V single end. The differential connection is recommended and the twisted pair wire is used suitably. The drive current is in the range of 8~15mA. The operation mode is set by parameter P035: Pulse + direction、Positive/Reverse pulse、A phase + B phase (orthogonal pulse).

There are three connection methods: differential drive, common single end drive and 24V single end drive. Differential drive connection is recommended. The wiring should be twisted pair. The driving current is 8~15mA. And the working mode is set by parameter P035: Pulse+ direction; CCW/CW pulse; A phase + B phase (orthogonal pulse).

Servo driver model is TL□□□□S0(Chapter 8.1), suitable for the following:

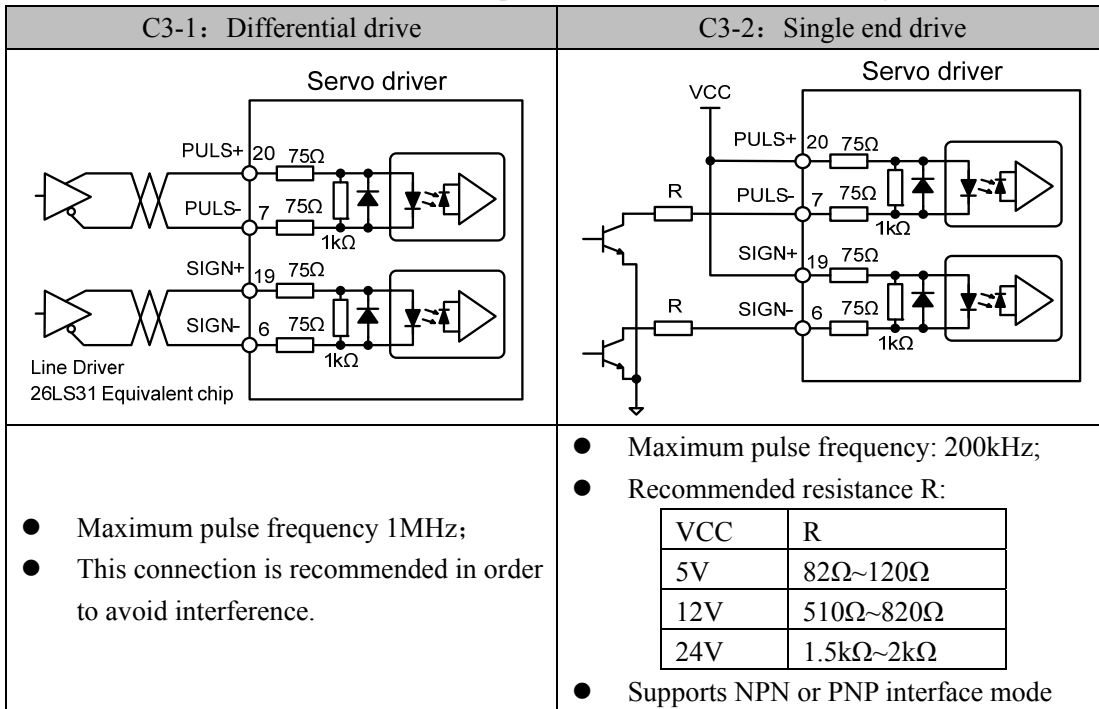

Servo driver model is □□□□S3(Chapter 8.1) , suitable for the following:

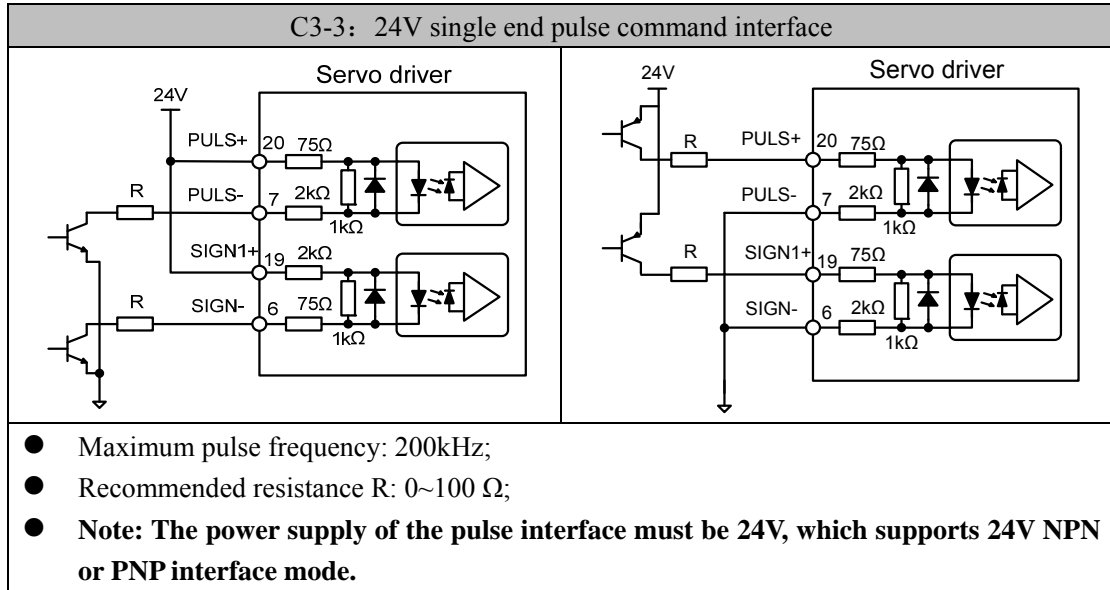

4. Analog command input interfaces (C4)

There are two connections: differential input and single ended input. Differential input connection is recommended. Speed and torque share one analog input. The input range is -10V~+10V, and the input impedance is about 10KΩ. It is normal for the analog input to have zero offset, which can be compensated by parameters.

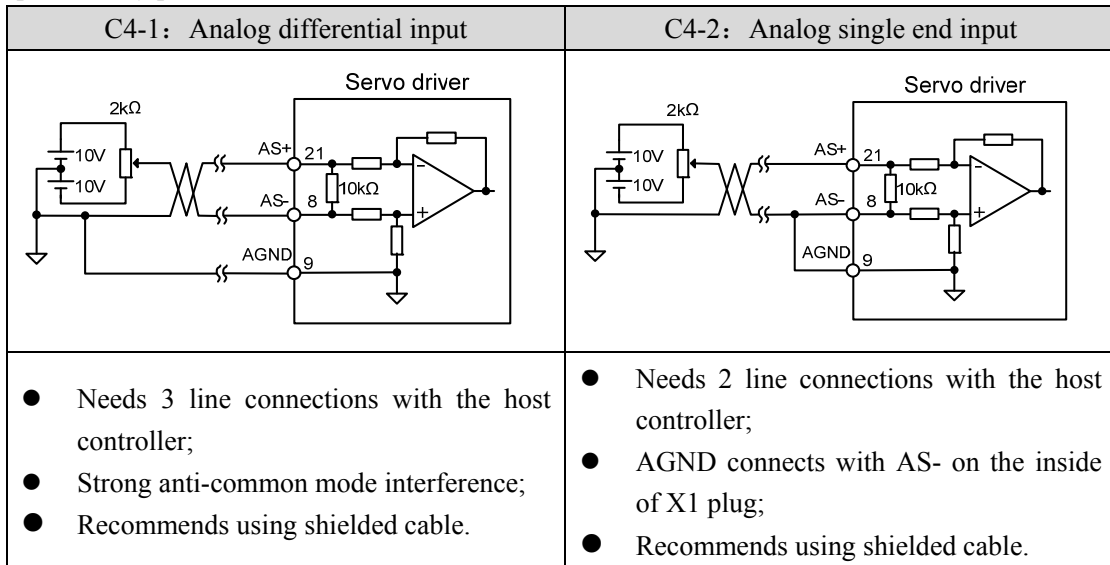

5. Encoder signal line drive output (C5)

Divide the encoder signal and output it to the host controller through the line driver.

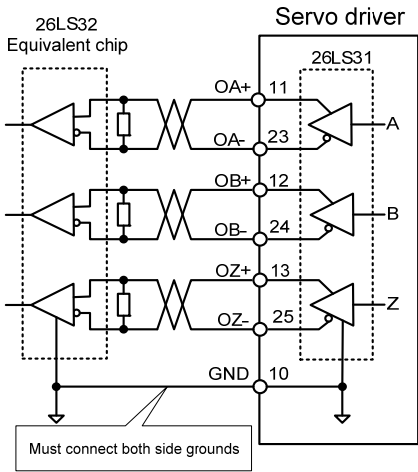
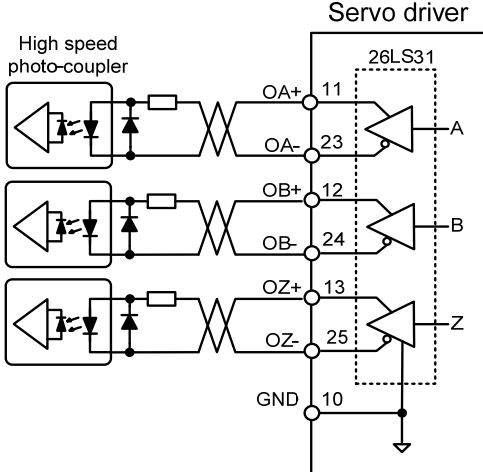
C5-1: Long line receiver	C5-2: Photoelectric coupler receiver
	
<ul style="list-style-type: none"> ● On the host controller uses AM26LS32(or equivalent) to make the receiver, must connect the terminal resistance, the value is $220\Omega\sim 470\Omega$; ● Encoder signal (GND) of servo driver must connect with the ground terminal on host controller. 	<ul style="list-style-type: none"> ● On host controller use high-speed photo coupler (e.g. 6N137); Current limiting resistor is about 220Ω.

6. Encoder Z signal collector open circuit output (C6)

The Z signal of the encoder is transferred to the host-controller through the open-collector circuit. Because the width of the Z pulse is narrow, please use a high-speed photo-coupler to receive it.

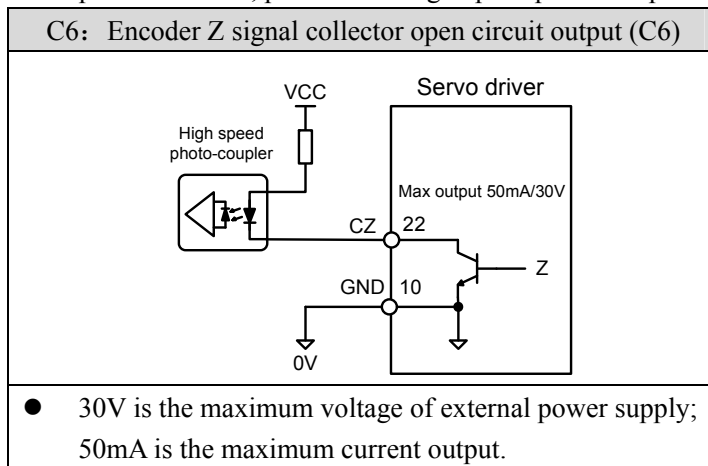

2.5 X2 encoder signal terminals

2.5.1 X2 terminal plug

Connection diagram of X2 encoder signal terminal and motor encoder:

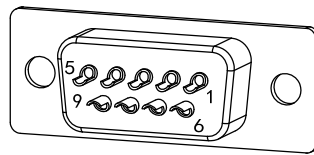
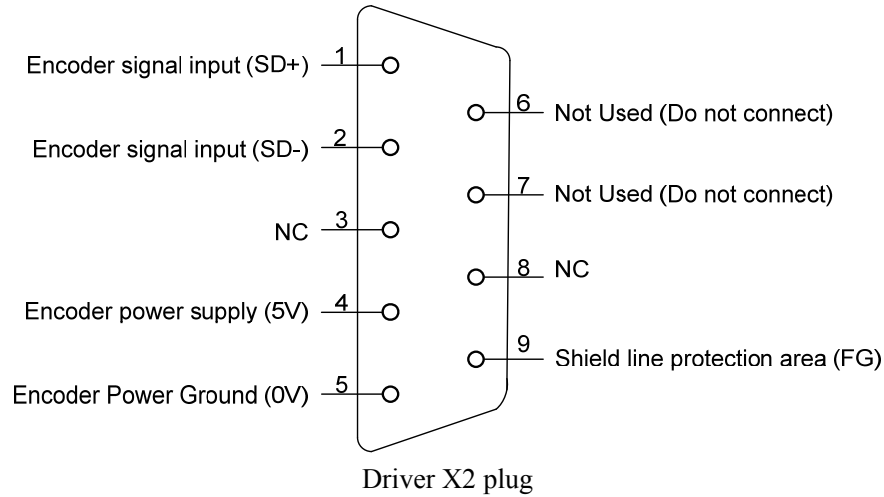

X2 plug welding pin distribution

2.5.2 X2 terminal signal description

Signal name		Pin number	Functions
		Absolute type (6 core)	
Encoder power supply	5V	4	Use 5VDC power supply (provided by servo driver).If the cable is longer than 20m, in order to prevent encoder from voltage drop down, it is better to use multi wire or thick wire for power line and ground line.
	0V	5	
Signal input	SD+	1	Connect with absolute encoder signal output.
	SD-	2	
Frame ground	FG	9	Connect with signal cable shielding line

Note: Maxsine supplies finished cables, including model E□□□-DB09□□A09 (for seat size 60mm and 80mm motor) and model E□□□-DB09□□H15 (for motors with seat size 110 and above).

2.6 X5、X6 terminals

2.6.1 X5、X6 terminals interface

This function is optional. If it is ordered, the order number is needed to be confirmed. Please refer to Chapter 8.1.

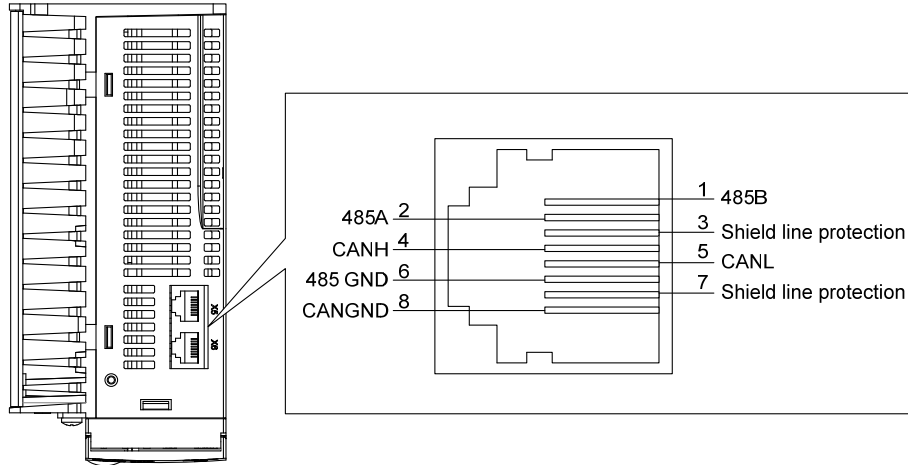

2.6.2 X5、X6 terminals signal description

Signal name		Pin number	Function
RS485 input output signal line	485B	1	Isolating 485B
	485A	2	Isolating 485A
	485 GND	6	RS485 ground
CAN input output signal line	CANH	4	Isolating CAN high level voltage input/output
	CANL	5	Isolating CAN low level voltage input/output
	CANGND	8	CAN GND
Shield ground	PE	7	GND
	PE	3	GND

Note: 1. this interface wiring is defined as the driver terminal

2. our company provides finished cables, model L□□□-ETH for RS485 communication.

2.7 Standard wiring diagram

2.7.1 Position control wiring diagram

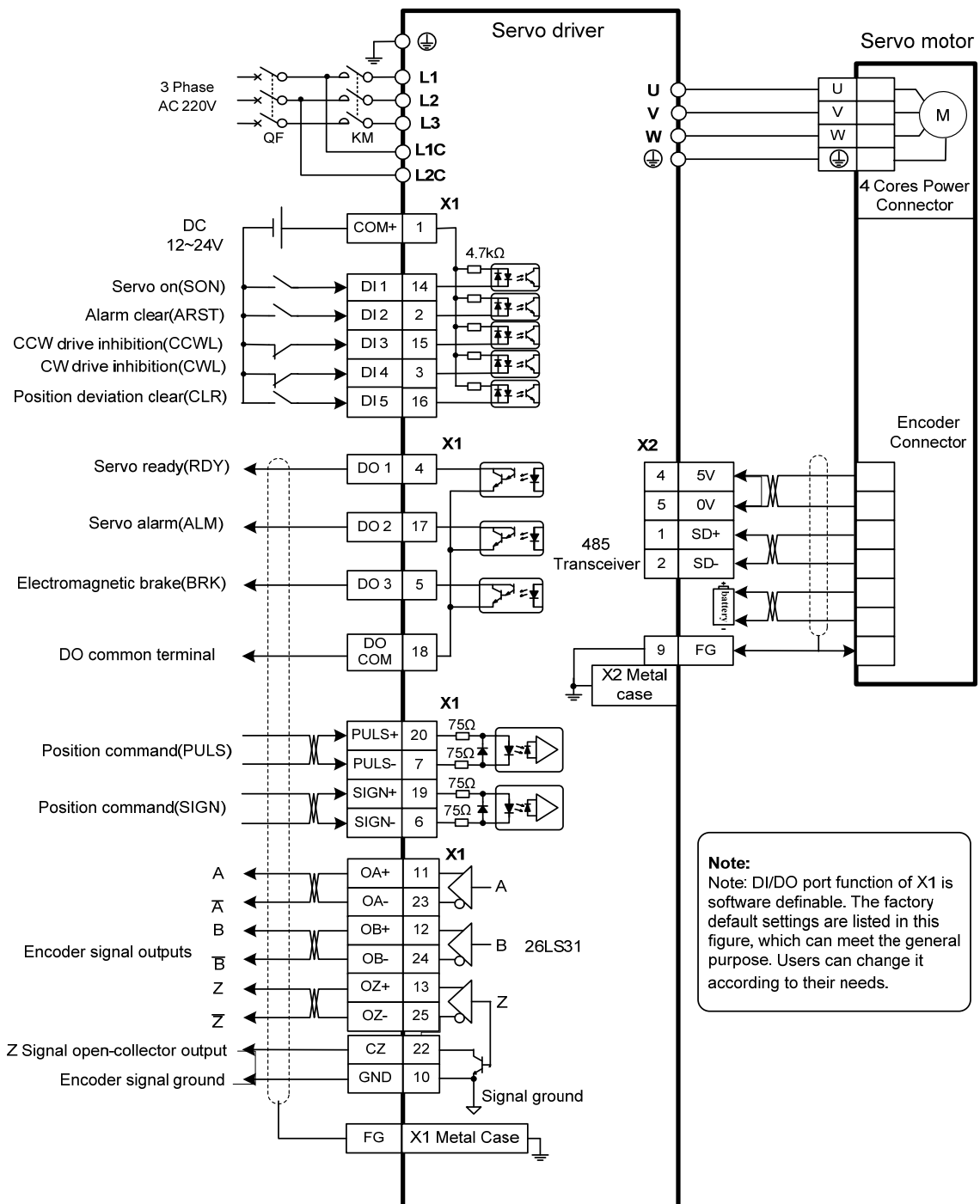

Note: TL10 is used as an example in the above wiring diagram.

2.7.2 Speed control or torque control wiring diagram

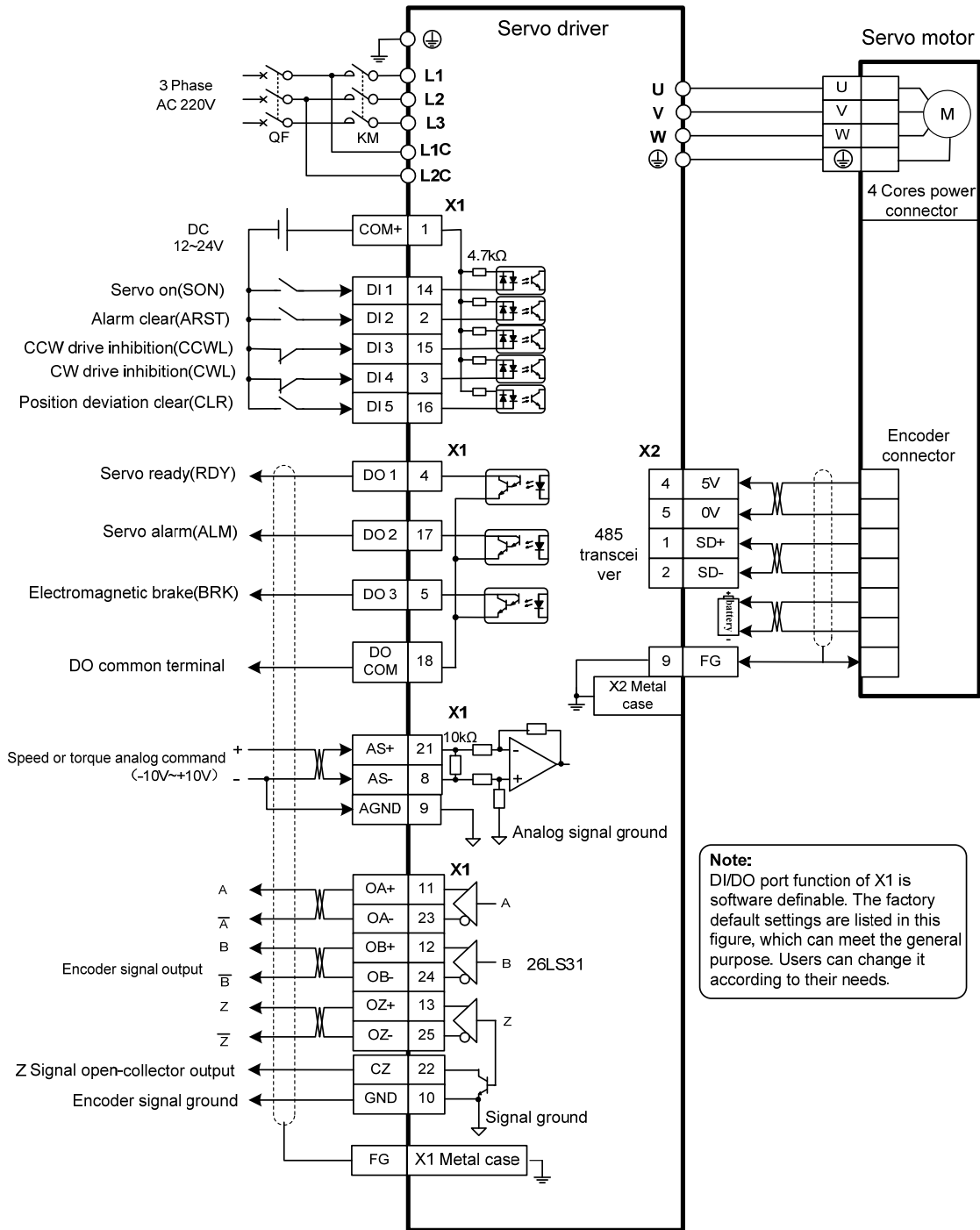





Note: TL10 is used as an example in the above wiring diagram.

Chapter 3 Front panel operation



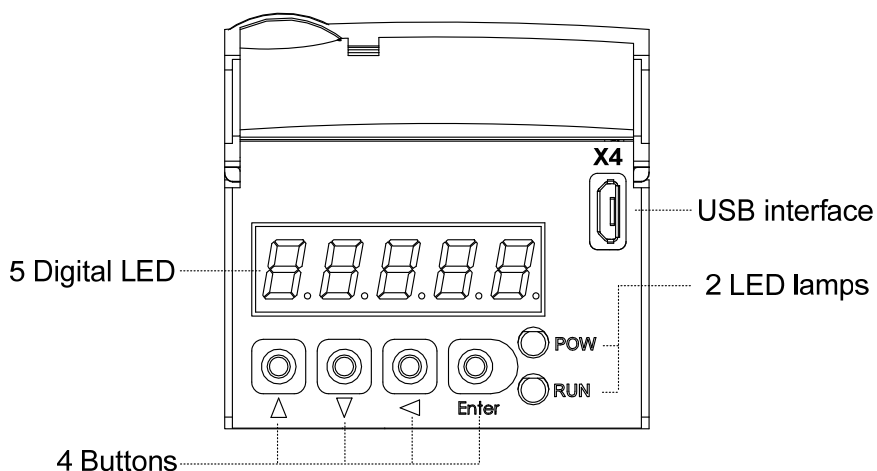

3.1 Driver front panel description

3.1.1 Front panel compositions

The front panel is composed of 5 LED digital tube displays, 4 buttons , , ,  and one USB interface, which are used to display various states of the system and set parameters. Operation is a hierarchical operation, which is expanded layer by layer from the main menu.



3.1.2 Front panel explanations

Symbol	Name	Functions
POW	Main power lamp	Lit: Main power supply already turn on; Go out: Main power supply did not turn on.
RUN	Running lamp	Lit: Motor is active; Go out: Motor is not active.
	Increasing button	Increase S/N or value; Long press has repeated effect
	Decreasing button	Decrease S/N or value; Long press has repeated effect
	Exit button	Menu exit; cancel the operation.
	Confirm button	Menu entered; the operation confirmed.
	USB interface	Equipment connected to the computer interface.

3.1.3 Data display

A number is shown by five digital displays; a minus symbol in front of the value represents a negative value; the lit decimal points in all the digits indicate a negative 5-digit value. Some displays have a prefix character. If the value is full-scale, then the prefix character can be omitted.

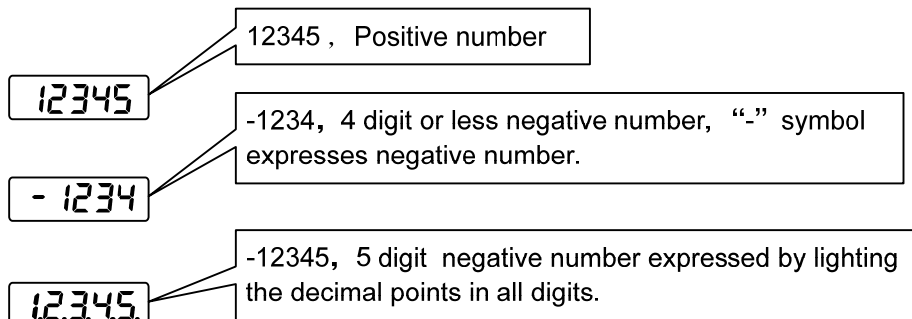



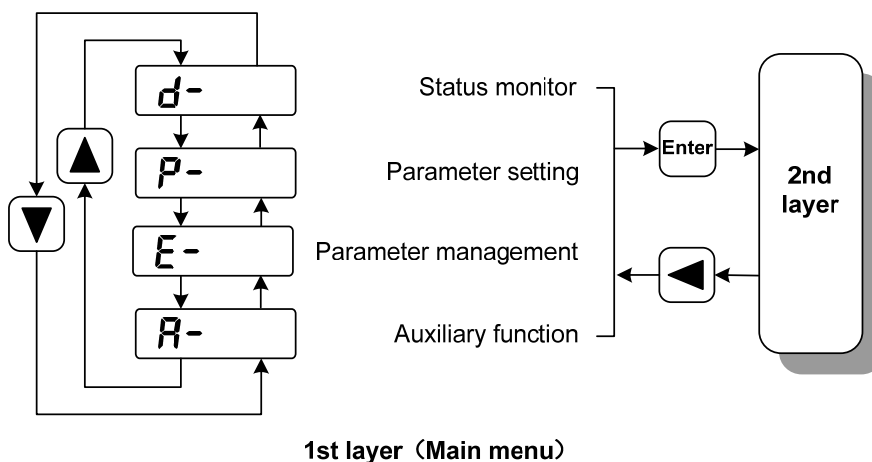

3.2 Main menu

The first layer is the main menu and has four operating modes. Pressing 、 button changes the operation mode. Pressing the button enters the second layer and then executes a concrete operation. Pressing button returns to the main menu from the second layer.



3.3 Status monitor

Choose status monitor "d-" under the main menu. Pressing the  button enters the monitor mode. There are many kinds of monitor's project; Use ,  button to select the needing project. Pressing the  button again enters the concrete status display.

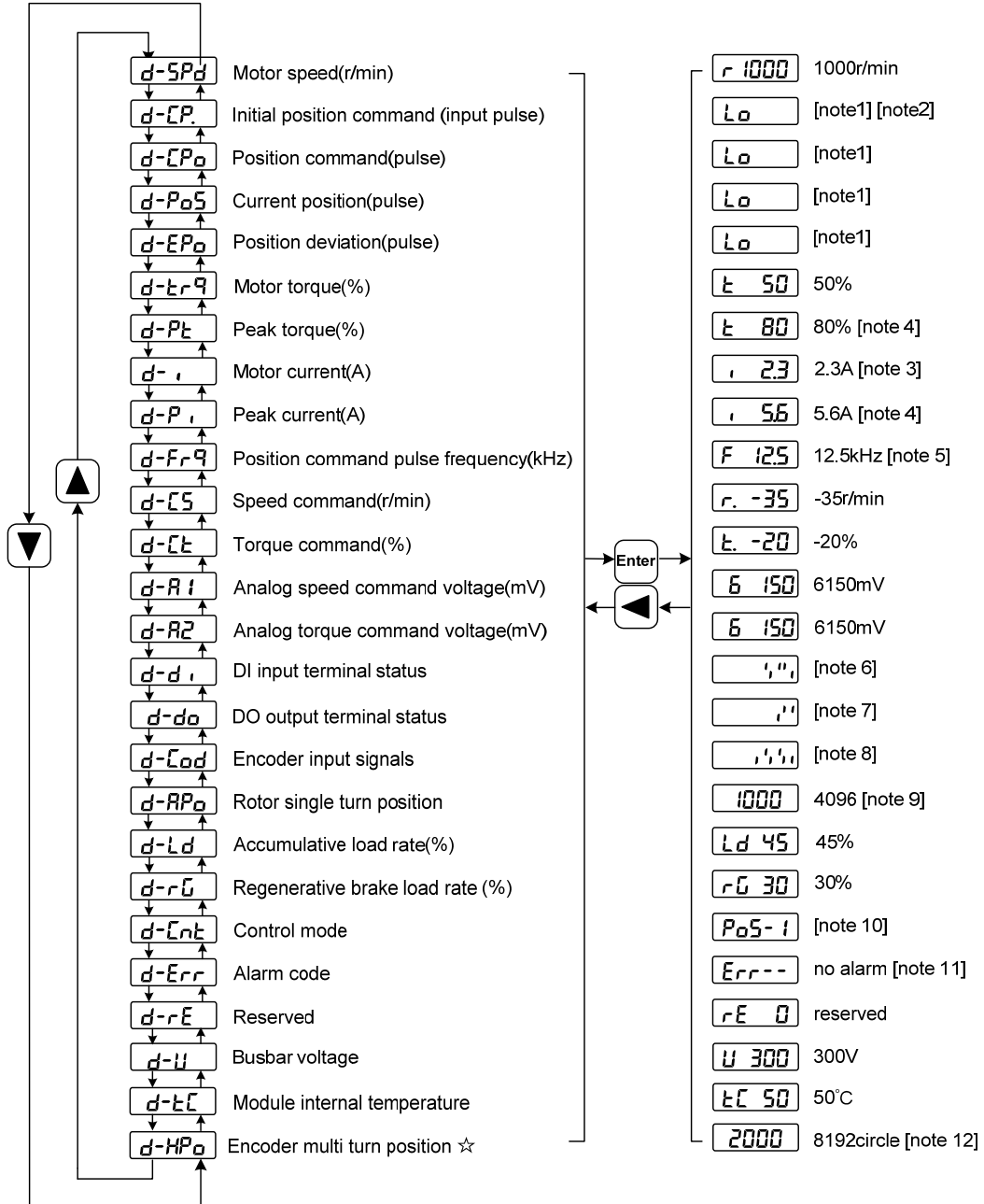

1. 32 binary bits value display [note1]

The range of 32-bit binary number is -2147483648~2147483647, which is represented by the combination of low and high digit. Select low digit and high digit through the menu, and use the formula in the figure to synthesize the complete value.

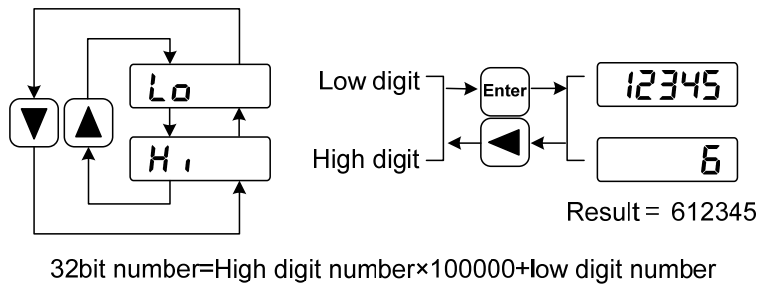

2. Pulse unit [note2]

The pulses of the initial position command refer to the number of pulses input without electronic gear transformation.

Other items of the pulse (position instruction, current position, position deviation, rotor absolute position) are uniform pulse units.

$$\text{Uniform pulse unit} = 65536 \text{ (pulse / rev)}$$

3. Motor current [note3]

Motor phase current effective value.

4. Peak torque and peak current [note 4]

Maximum torque and maximum effective phase current of the motor in the past 10 seconds.

5. Position command pulse frequency [note5]

Input the actual pulse frequency before the electronic gear is amplified (the pulse of the original position command). The positive number is displayed in the forward direction and the negative number is displayed in the reverse direction.

6. Input terminals DI [note6]

A vertical segment of LED shows an input status. The lit top vertical segment shows the DI input to be “ON” and the lit bottom vertical segment to be “OFF”.

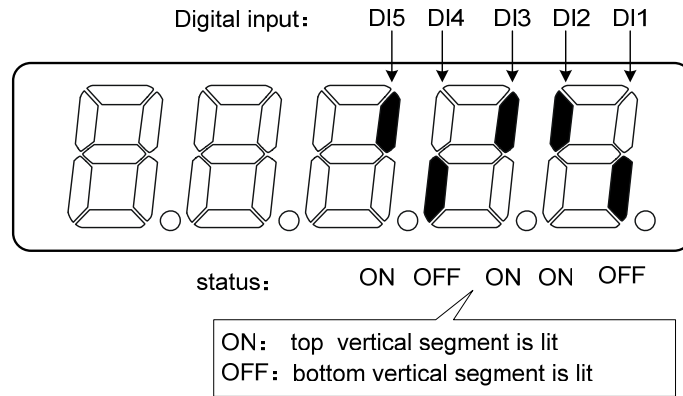

7. Output terminals DO [note7]

A vertical segment of LED shows an output status. The lit top vertical segment shows the DO output to be “ON” and the lit bottom vertical segment to be “OFF”.

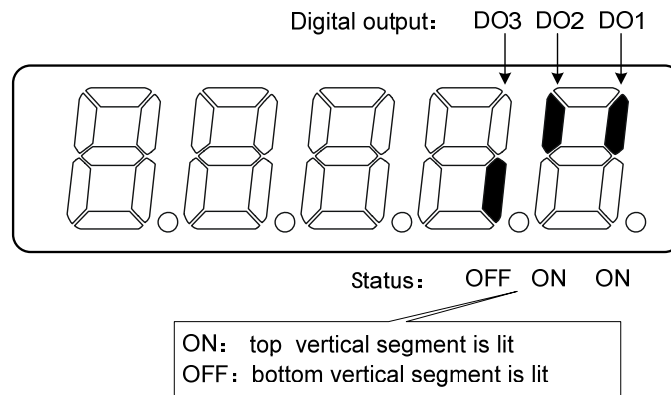

8. Encoder input signals [note8]

A vertical segment of LED shows an input status. The lit top vertical segment shows a High-level signal and the lit bottom vertical segment a Low-level signal.

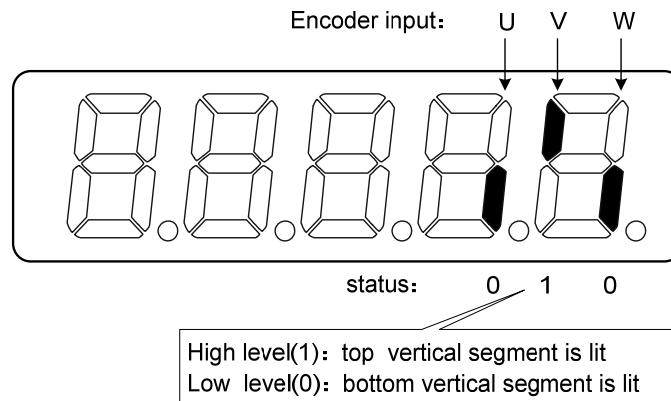

9. Rotor single turn position [note9]

Represents the position of the rotor relative to the stator in a revolution, and turns one into a period. The unified pulse unit takes the encoder Z pulse as the home. The range is 0~65535, and the value is 0 when the Z pulse appears.

10. Control mode [note10]

The first three characters show the control mode, the final character shows gain combination.

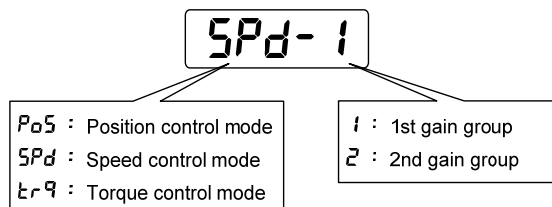

11. Alarm code [note11]

The "Err" followed by two minus symbols indicates no alarm and by digital number indicates an error code number that is flickering. When alarm appears, the error code number displays automatically on the front panel LED. During the error status, the monitor mode can be changed to other mode by pressing buttons, but the decimal point of the last LED is still flickering and shows existence of an alarm.

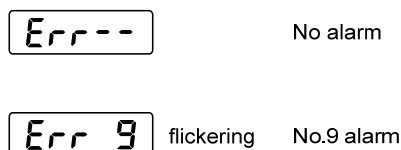

12. Encoder multi turn position [note12] ☆

This status shows that only absolute value drives are valid. Record the multi turn position of the encoder. With the single turn absolute position of the $RP0$ rotor, the absolute position of the rotor can be obtained:

Absolute position = multi turn position \times absolute encoder bit + single turn position

For example, the multi turn position displays 2000, and the single turn position displays 1000, both of which are decimal numbers







The absolute position of the encoder is $(2000 \times 2^{16} + 1000)$ (decimal) = 131073000











When the absolute value encoder is set to single turn mode (P090=0), the multi turn position is displayed as 0, which does not change with the rotor position.

In this operating instructions, "☆" means the special function of absolute encoder. "★" means the special function of incremental encoder. For software versions above V13.49, the incremental encoder is canceled.

3.4 Parameters setting

The parameter number expression uses a parameter section name combined with a parameter name. The three figures are the section name and two figures and one figure are the parameter name. Take P102 parameter as an example, '1' is the section name and '02' the parameter name. "P- 102" displays on the front panel LED.

Choose the parameter mode under the main menu "P- ". Pressing the  button enters the parameter-setting mode. First use ,  button to select the parameter section name and then pressing  button enters the parameter name selection. Again, use ,  button to select the parameter name and then pressing  button shows the parameter value.



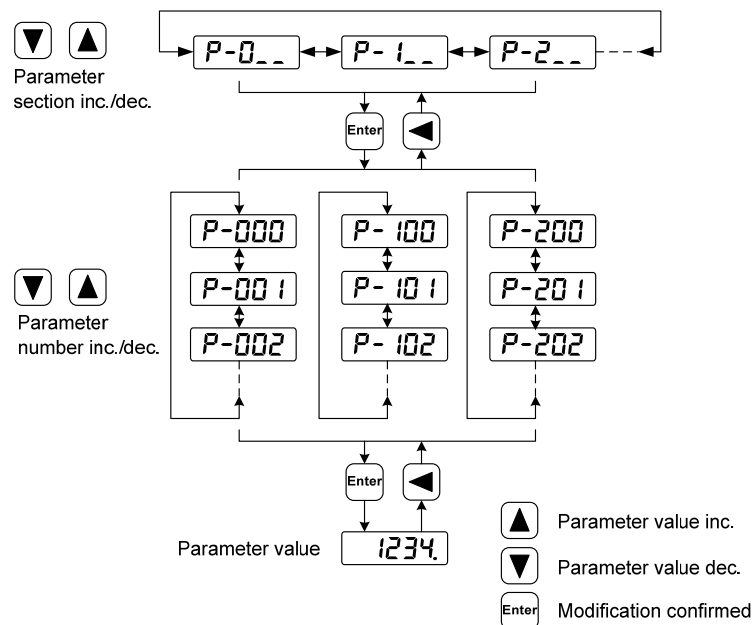

Use ,  button to alter a parameter value. Pressing ,  button once to increase or decrease the parameter value by one. Pressing down and hold the ,  button, the parameter value can increase or decrease continuously. When the parameter value is modified, the decimal point on the most right sides LED is lit. Press the  button to confirm the parameter value to be effective, meanwhile the decimal point turns off. The modified parameter value is immediately active to influence on the control action (but some parameters needs to preserve firstly and then turn off and on the power supply). Hereafter pressing  button returns to the parameter number selection and can continue to modify a parameter. If the value is not satisfied, do not press the  button and can press the  button to cancel it for resuming the original parameter value.

The modified parameter is not saved to EEPROM. If it needs to be saved permanently, please use the parameter write operation in parameter management. Parameter segments and Numbers are not necessarily contiguous, and unused segments and Numbers are skipped and cannot be selected.



3.5 Parameter management

Choose the parameter management mode under the main menu "E- ". Pressing the  button enters the parameter management mode. The operation is performed between parameter list and the EEPROM.

There are three operation modes. Use ,  button to select an operation mode and then pressing down and hold the  button at least three seconds to active the operation mode. After finished the operation and then pressing  button returns to the operation mode selection.

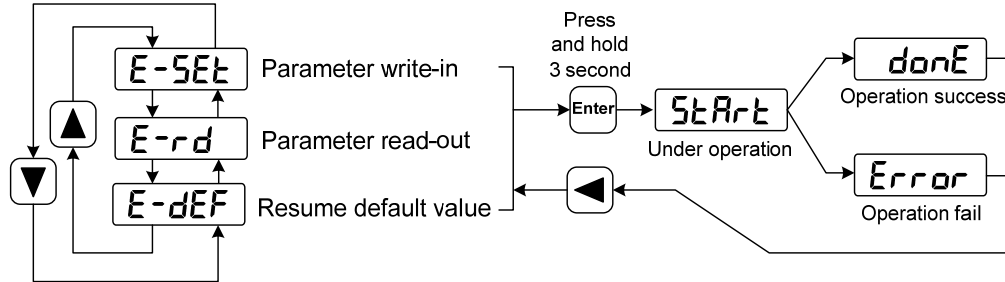

- **Parameter write-in**

This operation indicates that the parameter in the parameter list is written in EEPROM. The user modified the parameters, only changing the parameter values in the parameter list, and the original values will be restored when the power is turned on next time. If you want to permanently change the parameter value, you need to execute the parameter write in operation, and insert the parameter write in the parameter list into the EEPROM. After power on, the modified parameters will be used.

- **Parameter read-out**





This operation indicates that the data in EEPROM is read into the parameter list. This process will be automatically executed once when the power is turned on. At the beginning, the parameter values of the parameter list are the same as those in the EEPROM. However, if the user modifies the parameters, the parameter values in the parameter list will be changed. When the user is not satisfied with the modified parameters or the parameters are scrambled, the parameter read-out operation will be executed, and the data in the EEPROM can be read into the parameter list again to restore to the parameters just powered on.

- **Resume default value**

This operation indicates that the default values (factory values) of all parameters are read out in the parameter list and written in the EEPROM, and the default parameters will be used for the next power on. When the user adjusts the parameters disorderly and cannot work normally, use this operation to restore all parameters to the factory state. Because the default values of parameters corresponding to different driver models and motor models are different, the correctness of the motor code (parameter P002) must be ensured before using the default parameters to restore.



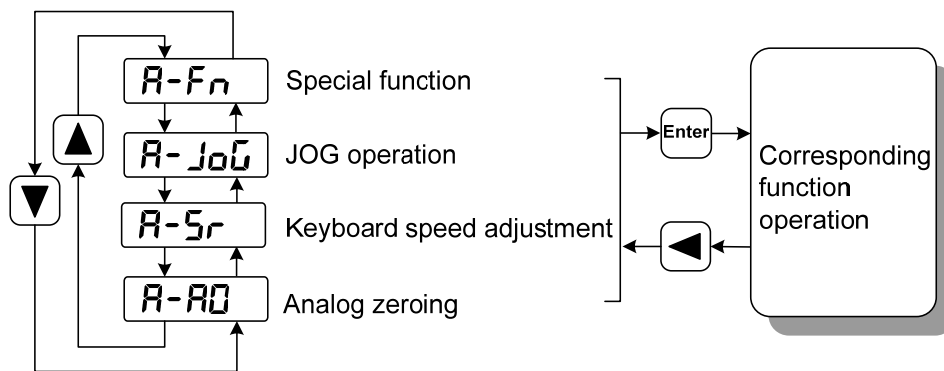

E-SEt	Parameter write-in:	Parameter list	⇒	EEPROM
E-rd	Parameter read-out:	Parameter list	⇐	EEPROM
E-dEF	Resume default value:	Ex-factory default value	⇒	Parameter list, EEPROM

3.6 Auxiliary functions

Select the auxiliary function "A-" in the main menu, and press the  button to enter the auxiliary function mode. Select the operation mode with ,  button. After selecting the operation, press the  button to enter the corresponding function, and then press the  button to return to the operation mode selection state.



3.6.1 Special functions☆

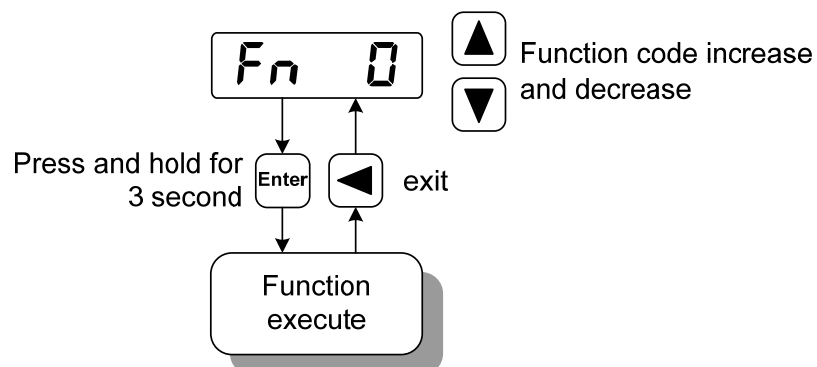

Select special functions and press the  button to enter. Set the function code with ,  button, press the  button and hold it for more than 3 seconds to activate the operation. After that, press the  button to exit.



Fn number	functions	explanation
Fn36	reset the encoder (multi-turn absolute encoder is valid)	Encoder RESET command, is used for encoder initialization, encoder alarm reset, and multi-turn information to zero. Perform this function after replacing the battery.
Fn37	Encoder alarm clearing	Encoder alarm clearing command is used to clear various encoder alarms. Executing this command will not clear the encoder multi turn information. Perform this function after replacing the battery.

3.6.2 Analog zeroing

After using this operation, the driver automatically detects the analog zero offset and writes the zero offset to the parameter P047 (or P054). This operation has saved the zero offset parameter to EEPROM, so there is no need to write the parameter.

Select analog zeroing "A-A0", press  button to enter. First select speed analog zeroing or torque analog zeroing through the menu, select the operation, press  button and hold for more than 3 seconds to activate the operation. After that, press the  button to return to the menu selection state.

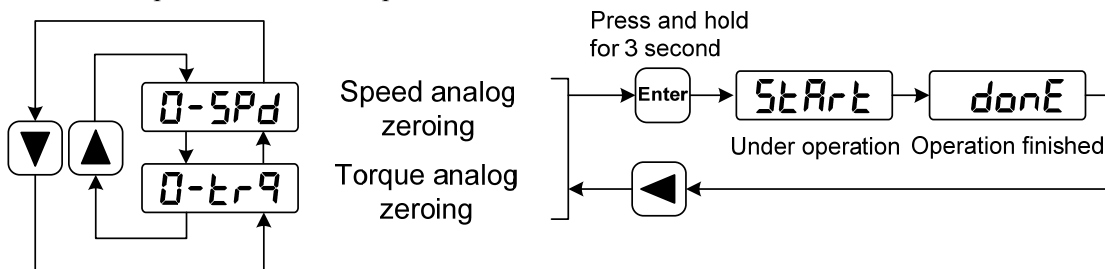

3.7 Resume the parameter default values

Please use the restore default parameters (factory parameters) function in the following cases:

- The parameters are scrambled, and the system cannot work normally.
- Replace the motor. The new motor is different from the original motor.

The steps to restore the default parameters are as follows:

Resume all of the parameter default value

All parameters are restored to their default values, and all user-modified parameters are restored to their factory defaults. Restore the default values in parameter management.

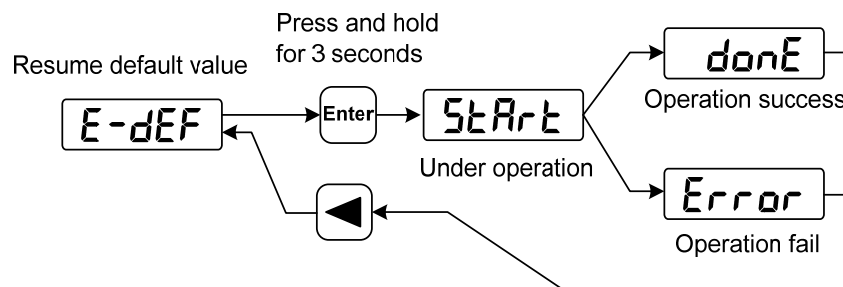

Resume all of the parameter default value

Turn off and on the power supply, then an operation can be performed again.

Chapter 4 Running

4.1 Trial running with no load

The purpose of the trial run is to confirm whether the following matters are correct:

- Driver power wiring;
- Servo motor power wiring;
- Encoder wiring;
- Running direction and speed of servo motor.

4.1.1 Wiring and inspection

Before turn on power supply, confirm that the motor:

- When the motor is unloaded, do not add load to the motor shaft, and disconnect the connector if it has been installed on the machine.
- Since the acceleration and deceleration of the motor have impact, the motor must be fixed.

Inspect the following items before turn on power supply:

- Is the connection correct? In particular, whether the driver U, V, W is one-to-one corresponding to the motor U, V, W wiring and whether the driver L1, L2, L3, L1C, L2C, 24V, 0V wiring.
- Is the input voltage correct?
- Is the encoder cable connected correctly?

4.1.2 Trial running in JOG mode

1. Before performing this operation, confirm that the motor has been disconnected from the load.
2. Turn on the power supply (AC 3-phase 220V or AC 1-phase 220V). The front panel display is lit and the POWER indicating LED is lit. If any error alarm, please inspect the wiring.
3. After confirming that there is no alarm or abnormality, perform the following operations as shown below:

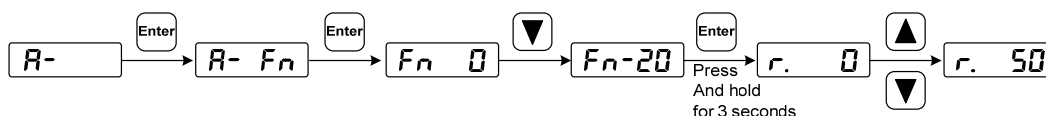

Change the speed command by ▲, ▼ button, and the motor runs at the given speed. Positive number indicates forward rotation (CCW), negative number indicates reverse rotation (CW), and the minimum given speed is 0.1r/min.

Note: After the Fn function is executed, the E-SET saving operation cannot be performed, and the power must be turned off and restarted, otherwise the state of Fn will be saved.

4.2 Position control mode

Position control mode is applied to the systems requiring precise positioning, such as CNC machine tools, textile machinery, etc. The source of position command is pulse command, which is input by PULS+, PULS- and SIGN+, SIGN- of the input terminal.

4.2.1 Simple example of position control mode

This is a simple example of the position control mode. The following figure is the wiring diagram.

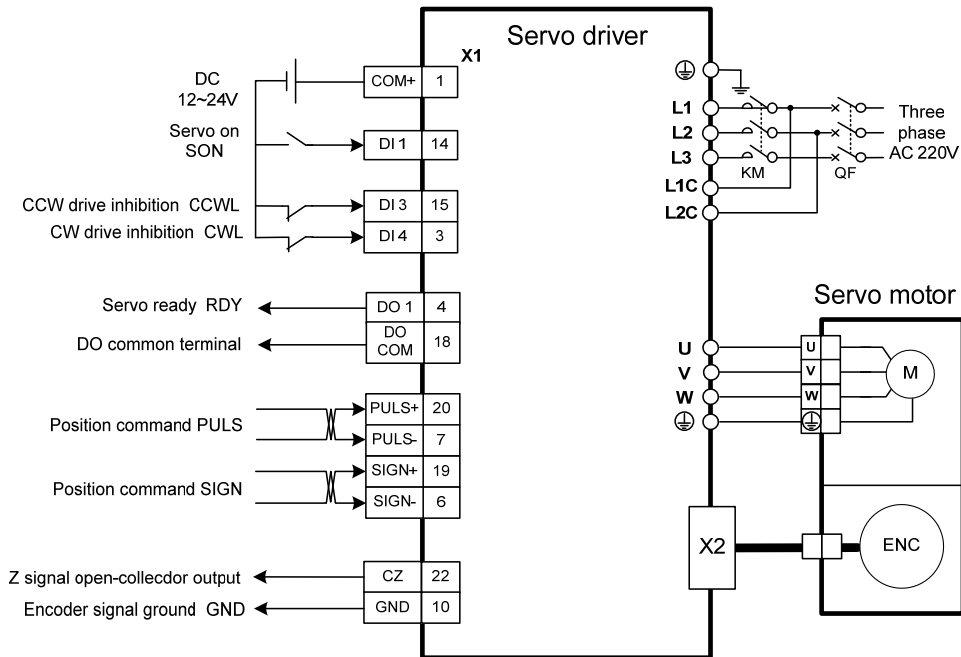

Example parameter settings:

Parameter	Name	Setting value	Default value	Parameter explanation
P004	Control mode	0	0	Set position control mode
P097	Ignore drive inhibit	3	3	Use forward drive inhibit (CCWL) and reverse drive inhibit (CWL). If set to ignore, did not connect CCWL、CWL.
P100	Digital input DI1 function	1	1	Set DI1 for servo enable (SON)
P130	Digital output DO1 function	2	2	Set DO1 for servo is ready(RDY)

4.2.2 Position command

1. Parameters related to position command

Parameter	Name	Range	Default value	Unit	Usage
P027	Encoder pulse factor 1 [note]	1~32767	10000		P
P028	Encoder pulse factor 2 [note]	1~32767	1		P
P029	1 st numerator of command pulse electronic gear	1~32767	1		P
P030	Command pulse electronic gear denominator	1~32767	1		P
P031	2 nd numerator of command pulse electronic gear	1~32767	1		P
P032	3 rd numerator of command pulse electronic gear	1~32767	1		P
P033	4 th numerator of command pulse electronic gear	1~32767	1		P
P035	Command pulse input mode	0~2	0		P
P036	Command pulse input direction	0~1	0		P
P037	Command pulse input signal logic	0~3	0		P
P038	Command pulse input signal filtering	0~21	0		P
P039	Command pulse input filtering mode	0~1	0		P
P040	Position command exponential smoothing filter time	0~1000	0	ms	P

Note: By default (the electronic gear ratio is 1:1), the number of command pulses required for the motor to rotate for one cycle= $P027 \times P028$.



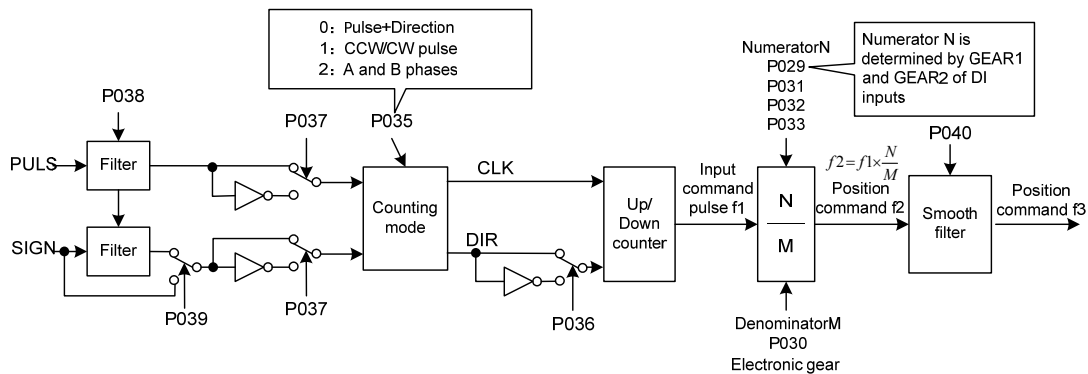

Users need to make sure the result of $P027 \times P028$ is less than or equal to 131072.

2. Command pulse transmission path

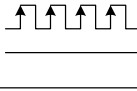

3. Command pulse input mode

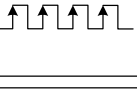
The input mode is determined by parameter P035. The input signal PULS and SIGN signal phases can be set by parameter P037 to adjust the counting edge. Parameter P036 is used to change the counting direction.

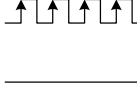
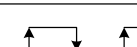
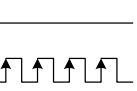
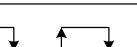
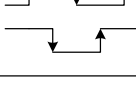
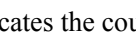
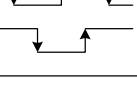
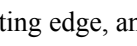
Pulse command form	CCW	CW	Parameter P035
Pulse + direction	PULS  SIGN 	PULS  SIGN 	0
CCW pulse/ CW pulse	PULS  SIGN 	PULS  SIGN 	1
Orthogonal pulse	PULS  SIGN 	PULS  SIGN 	2

Note: The arrow indicates the counting edge, and P036=0, P037=0.

4. Pulse command timing chart specification

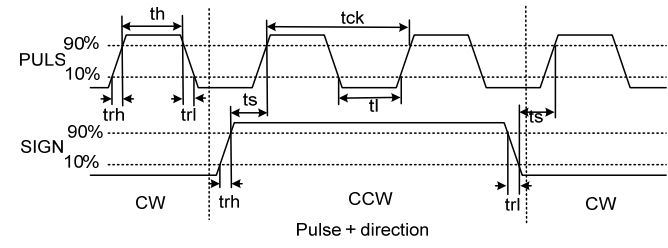
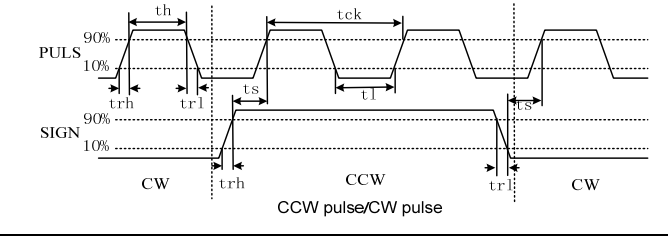
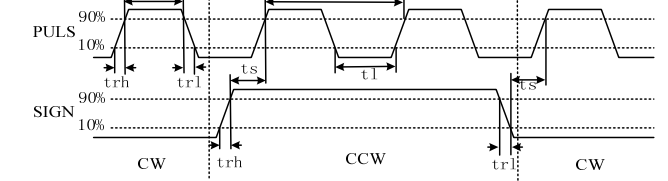
Position command pulse waveform	Parameter demand	
	Differential	single-ended
 <p>Pulse + direction</p>	$t_{ck} > 2\mu s$ $t_h > 1\mu s$ $t_l > 1\mu s$	$t_{ck} > 5\mu s$ $t_h \gg 2.5\mu s$ $t_l \gg 2.5\mu s$
 <p>CCW pulse/CW pulse</p>	$t_{rh} < 0.2\mu s$ $t_{rl} < 0.2\mu s$ $t_s > 1\mu s$ $t_{qck} > 8\mu s$ $t_{qh} > 4\mu s$ $t_{ql} > 4\mu s$	$t_{rh} < 0.3\mu s$ $t_{rl} < 0.3\mu s$ $t_s > 2.5\mu s$ $t_{qck} > 10\mu s$ $t_{qh} > 5\mu s$ $t_{ql} > 5\mu s$
 <p>Orthogonal pulse</p>	$t_{qrh} < 0.2\mu s$ $t_{qrl} < 0.2\mu s$ $t_{qs} > 1\mu s$	$t_{qrh} < 0.3\mu s$ $t_{qrl} < 0.3\mu s$ $t_{qs} > 2.5\mu s$

5. Signal filter

Parameter P038 sets the input signal PULS and SIGN digital filtering. The larger the value is, the larger the filtering time constant is. By default, the maximum pulse input frequency is 1000 kHz (kpps). The larger the value, the lower the maximum pulse input frequency.

It is used to filter the noise on the signal line to avoid counting errors. In case of inaccurate counting, increase the parameter value appropriately. Parameter P039 turns off the filtering of the SIGN signal.

6. Smooth filter

As shown in the figure below, parameter P040 is used to smooth and filter the command pulse, with exponential acceleration and deceleration. The filter will not lose the input pulse, but there will be command delay. When set to 0, the filter does not work. The parameter value represents the time when the frequency rises from 0 to 63.2% of the position command frequency.

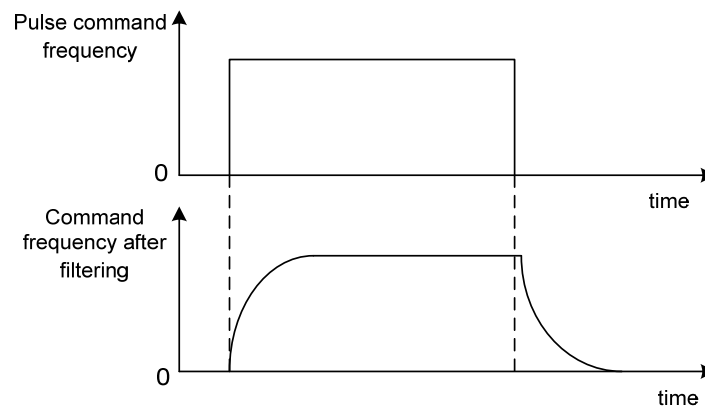

The filter smoothes the input pulse frequency. This filter is used for: Host controller has no acceleration and deceleration function, the electronic gear is relatively large, and the command frequency is low.

4.2.3 Input electronic gear

The unit pulse command input to the device can be defined through the electronic gear to make the transmission device move any distance. The pulse command generated by the host controller does not need to consider the gear ratio, reduction ratio of the transmission system or the number of motor encoder lines. The following table describes the electronic gear variables:

Variable	Explanation	Value of this driver
P_t	Resolution of motor every turn (pulse/rev)	P027×P028 =10000×1 =10000(pulse/rev)
R	Reduction ratio	As the incremental type
ΔP	One command pulse travel equivalent	
P_c	Command pulse numbers in one turn of load shaft	
$Pitch$	Pitch of ball bearing screw (mm)	
D	Diameter of rolling cylinder (mm)	

Calculating formula:

$$\text{Electronic gear ratio} \left(\frac{N}{M} \right) = \frac{\text{Resolution of motor every turn}(P_t)}{\text{Command pulse number in one turn of load shaft}(P_c) \times \text{Reduction ratio}(R)}$$

Here,

$$\text{command pulse number in one turn of load shaft}(P_c) = \frac{\text{Movement quantity in one turn of load shaft}}{\text{Movement quantity in one command pulse}(\Delta P)}$$

The calculated result will be abbreviated and make the numerator and the denominator smaller or equal to 32767 integer values. At last, the result must be in the range of $1/50 < N/M < 200$ and write to the parameter list.

1. Electronic gear in ball screw applications

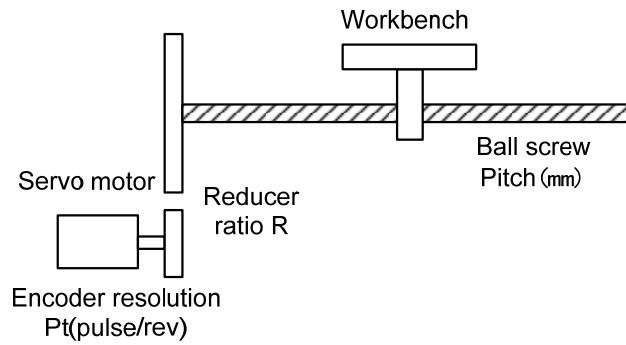

The ball bearing screw load has

$$\text{Electronic gear ratio} \left(\frac{N}{M} \right) = \frac{P_t}{P_c \times R}$$

Here,

$$P_c = \frac{\text{Pitch}}{\Delta P}$$

For example:

Known, reduction ratio 1/1, Pitch=8mm, one pulse travel equivalent $\Delta P=0.001\text{mm}$, calculate the electronic gear ratio.

Calculation steps:

- Calculate the resolution of motor every turn (P_t)

$$P_t = P_{027} \times P_{028} = 10000 \times 1 = 10000 \text{ (pulse / rev)}$$

- Calculate the command pulse number in one turn of load shift (P_c)

$$P_c = \frac{\text{Pitch}}{\Delta P} = \frac{8\text{mm}}{0.001\text{mm}} = 8000$$

- Calculate the electronic gear ratio.

$$\text{Electronic gear ratio} \left(\frac{N}{M} \right) = \frac{P_t}{P_c \times R} = \frac{10000}{8000 \times (1/1)} = \frac{5}{4}$$

- Set parameters (By first numerator as an example)

Numerator $N=5$, denominator $M=4$, set $P_{029}=5$ and $P_{030}=4$.

2. Relationship between number of the motor rotation turns and electronic gear ratio

The relationship between the number of motor rotation turns and the electronic gear is:

$$\text{Motor rotations turn number}(r / \text{min}) = \frac{f(\text{Hz}) \times 60 \times N}{P_t \times M}$$

Among them, pulse is the number of input pulses. For example, the motor resolution every turn $P_t=10000$, $N=20$, $M=3$, pulse=1000, calculated as:

$$\text{Motor rotations turn number} = \frac{1000 \times 20}{10000 \times 3} = \frac{2}{3} (\text{Turn})$$

3. Relationship between motor rotation speed and electronic gear ratio

The relationship between motor rotation speed and electronic gear is:

$$\text{Motor speed}(r / \text{min}) = \frac{f(\text{Hz}) \times 60 \times N}{P_t \times M}$$

Among them, f is the input pulse frequency, in Hz (pps), for example, the resolution of motor every turn $P_t=10000$, $N=3$, $M=1$, $f=100\text{kHz}$ (kpps), calculated as:

$$\text{Motor speed}(r / \text{min}) = \frac{100 \times 10^3 \times 60 \times 3}{10000 \times 1} = 1800 (r / \text{min})$$

4. Electronic gear ratio switching

The driver provides four groups of electronic gear numerator N , which can be changed online and determined by GEAR1 and GEAR2 input by DI. The denominator M is the same.

DI signal[<i>note</i>]		Input electronic gear numerator N	Input electronic gear denominator M
GEAR2	GEAR1		
0	0	1 st numerator(parameterP029)	Denominator(parameterP030)
0	1	2 nd numerator(parameterP031)	
1	0	3 rd numerator(parameterP032)	
1	1	4 th numerator(parameterP033)	

Note: 0 indicates OFF; 1 indicates ON.

4.2.4 Position control mode related gain

Parameter	Name	Range	Default value	Unit	Usage
P009	1st position loop gain	1~1000	40	1/s	P
P021	Position loop feedforward gain	0~100	0	%	P
P022	Position loop feedforward filter time constant	0.20~50.00	1.00	ms	P

Because the position loop includes the speed loop, first set the load moment of inertia ratio, then adjust the speed loop gain, speed loop integration time constant, and finally adjust the position loop gain according to the order of inner loop to outer loop.

The following is the position controller of the system. Increasing the gain K_p of the position loop can improve the bandwidth of the position loop, but it is limited by the bandwidth of the speed loop. To increase the gain of position loop, the bandwidth of speed loop must be increased first.

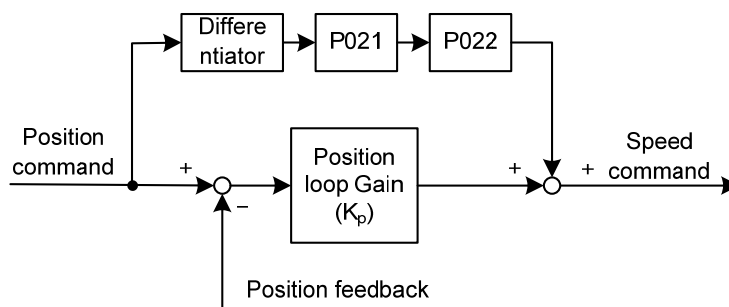

Feedforward can reduce the phase lag of position loop control, reduce the position tracking error and shorten the positioning time. With the increase of feedforward, the tracking error of position control is reduced, but if it is too large, the system will be unstable and overshoot. If the electronic gear ratio is greater than 10, it is also easy to generate noise. In general applications, P021 can be set to 0%. When high response and low tracking error are required, they can be increased appropriately, and should not exceed 80%. At the same time, it may be necessary to adjust the position loop feedforward filter time constant (parameter P022).

4.3 Speed control mode

Speed control mode is applied to the occasions requiring precise speed control, such as braider, drill, CNC machine. Position control can also be formed by host device.

4.3.1 Simple example of speed control mode

This is a simple example of speed control mode (analog speed command input). The following figure is the wiring diagram.

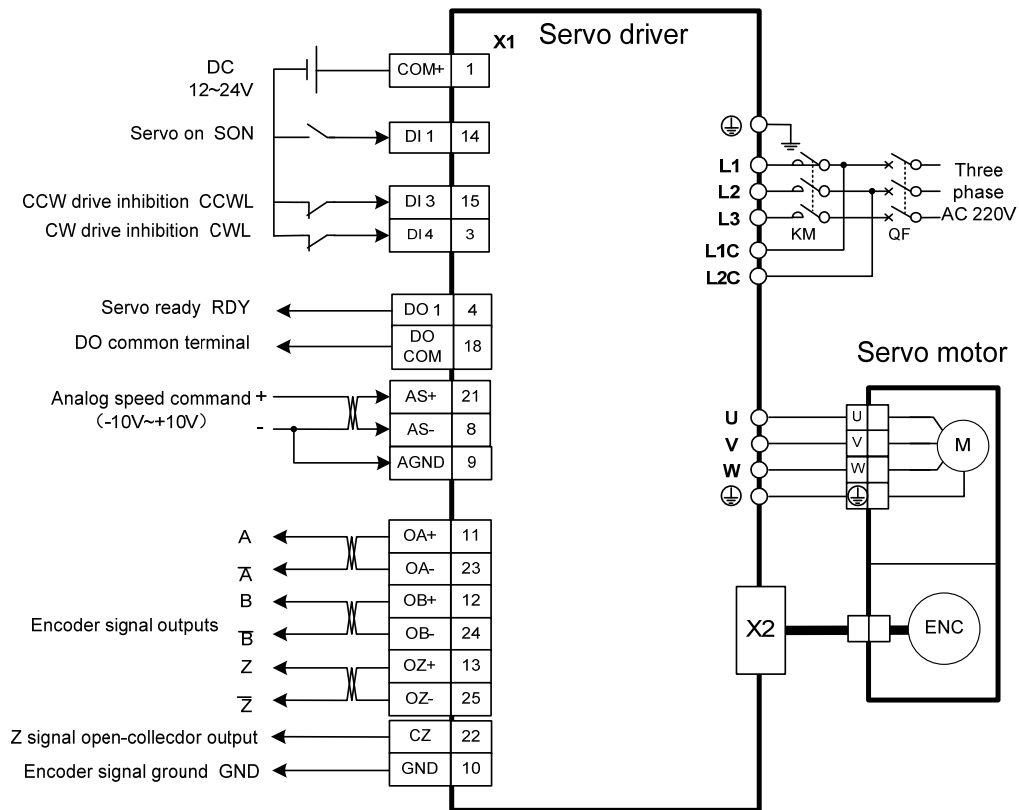

Example parameter settings:

Parameter	Name	Setting value	Parameter explanation
P004	Control mode	1	Set speed control mode.
P025	Speed command source	0	Set analog input.
P060	Speed command acceleration time	suitable	
P061	Speed command deceleration time	suitable	
P097	Ignore drive inhibit	3	Use forward drive inhibit (CCWL) and reverse drive inhibit (CWL). If set to ignore, did not connect CCWL、CWL.
P100	Digital input DI1 function	1	Set DI1 for servo enable (SON)
P130	Digital output DO1 function	2	Set DO1 for servo is ready(RDY)

4.3.2 Parameters related to speed command

The following table is the parameters related to the speed command:

Parameter	Name	Range	Default value	Unit	usage
P025	Speed command source	0~6	0		S
P046	Analog speed command gain	10~3000	300	r/min/V	S
P047	Analog speed command zero offset compensation	-1500.0~1500.0	0.0	mv	S
P048	Analog speed command direction	0~1	0		S
P049	Analog speed command filter time constant	0.20~50.00	2.00	ms	S
P050	Analog speed command polarity	0~2	0		S
P051	Analog speed command dead zone 1	0~13000	0	mv	S
P052	Analog speed command dead zone 2	-13000~0	0	mv	S
P076	JOG running speed	0~7500	100	r/min	S

4.3.3 Speed command source

Speed command has several different sources, which are set by parameter P025:

P025	Explanation	Interpret
0	Analog speed command	From terminal AS+ and AS- inputs analog voltage
1	Internal speed command	Determined by the SP1, SP2, SP3 DI input
3	JOG speed command	Set for JOG operation.
4	Keyboard speed command	Set for Keyboard speed adjustment (Sr) operation
5	Demonstration speed command	Set for speed regulation demonstration

Note: Internal speed command:

DI Signals			Speed command
SP3	SP2	SP1	
0	0	0	Internal speed 1 (parameter P137)
0	0	1	Internal speed 2 (parameter P138)
0	1	0	Internal speed 3 (parameter P139)
0	1	1	Internal speed 4 (parameter P140)
1	0	0	Internal speed 5 (parameter P141)
1	0	1	Internal speed 6 (parameter P142)
1	1	0	Internal speed 7 (parameter P143)
1	1	1	Internal speed 8 (parameter P144)

Above 0 indicates OFF; 1 indicates ON. Two DI inputs CZERO (zero command) and CINV (reverse command) can provide special functions. When CZERO is ON, the speed command is forced to zero; When CINV is ON, the speed command is reversed.

4.3.4 Acceleration and deceleration

The following parameters relate to acceleration and deceleration:

Parameter	Name	Range	Default value	Unit	Usage
P060	Speed command acceleration time	0~30000	0	ms	S
P061	Speed command deceleration time	0~30000	0	ms	S
P063	EMG(emergency shutdown) deceleration time	0~10000	1000	ms	ALL

Acceleration and deceleration can slow down the sudden change of speed and make the motor run smoothly. As shown in the figure below, parameter P060 sets the acceleration time of the motor from zero speed to rated speed, and P061 sets the deceleration time of the motor from rated speed to zero speed. If the command speed is lower than the rated speed, the required acceleration and deceleration time will be shortened accordingly. If the driver and host device constitute position control, the parameter should be set to 0.

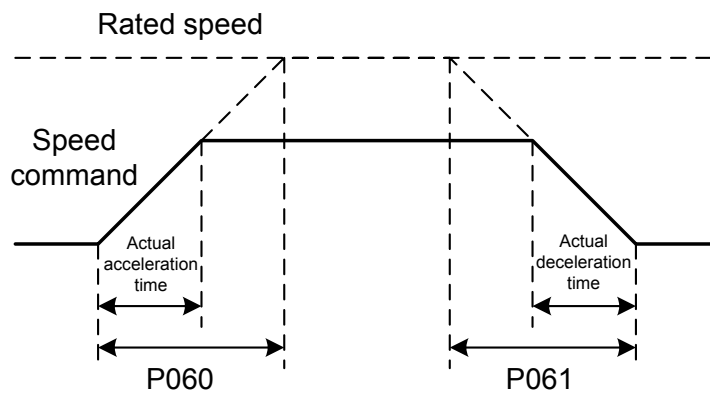

4.3.5 Zero speed clamp

Parameters related to zero speed clamp:

Parameter	Name	Range	Default value	Unit	Usage
P160	Zero speed detection point	0~1000	10	r/min	ALL
P161	Zero speed detection back error	0~1000	5	r/min	ALL
P162	Zero speed clamp mode	0~1	0		S

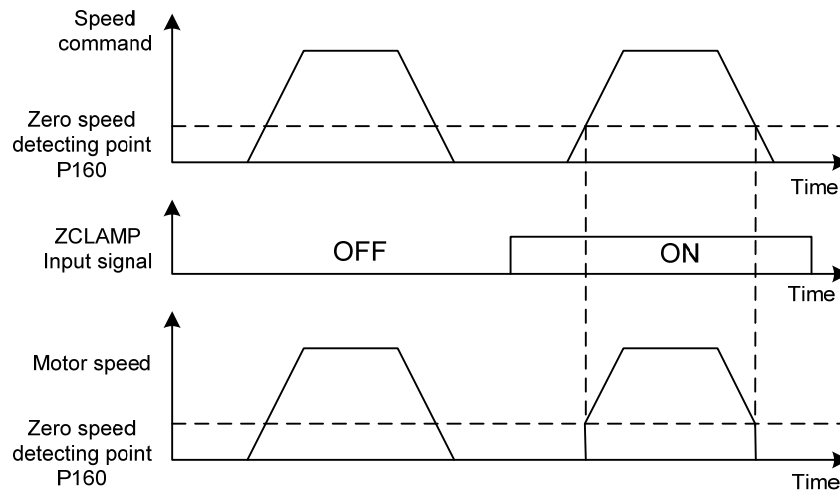

In speed control mode, even if the motor is at zero speed, external force may rotate and cause position change. If the analog speed command is input, the absolute zero speed command is not easy to implement. To solve these two problems, the zero speed clamping function can be considered. The zero speed clamping function is enabled when the following conditions are met:

- Condition 1: Speed control mode;
- Condition 2: ZCLAMP (zero speed clamping) in DI is ON;
- Condition 3: Speed command is lower than parameter P160.

If any of the above conditions are not met, normal speed control shall be performed. There are two modes of zero speed clamping:

P162	Explanation
0	The motor position is fixed at the moment when the function is turned on. At this time, the internal access position control will return to the zero fixed point even if the rotation occurs due to external force.
1	When the function is turned on, the speed command is forced to zero speed. The internal control is still speed control, which may rotate due to external forces.

4.3.6 Speed control mode related gain

Parameter	Name	Range	Default value	Unit	Usage
P005	1st speed loop gain	1~3000	40	Hz	P,S
P006	1st speed loop integral time constant	1.0~1000.0	20.0	ms	P,S
P010	2nd speed loop gain	1~3000	40	Hz	P,S
P011	2nd speed loop integral time constant	1.0~1000.0	10.0	ms	P,S
P017	Load moment of inertia ratio	0.0~200.0	1.0	times	P,S
P018	Speed loop PDFF control coefficient	0~100	100	%	P,S

First, set the load moment of inertia ratio, and then adjust the speed loop gain and speed loop integration time constant. The following is the speed controller of the system. Increasing the speed loop gain K_v can improve the speed response bandwidth, and decreasing the speed loop integration time constant T_i can increase the system rigidity and reduce the steady-state error.

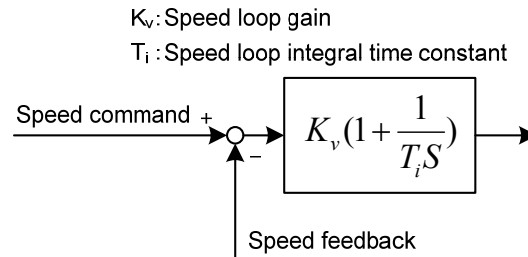

P018 can choose the speed controller structure. 0 is the IP regulator, 100 is the PI regulator, 1~99 is the PDFF regulator. If the parameter value of P018 is too large, the system has high frequency response; if the parameter value is too small, the system has high stiffness (resistance to deviation); if the parameter value is too small, both frequency response and stiffness are considered.

4.4 Torque control mode

Torque control mode is used for printing, winding machines, injection molding machines and other occasions. The motor output torque is proportional to the input command.

4.4.1 Simple example of torque control mode

This is a simple example of torque control mode (analog torque command input). The following figure is the wiring diagram.

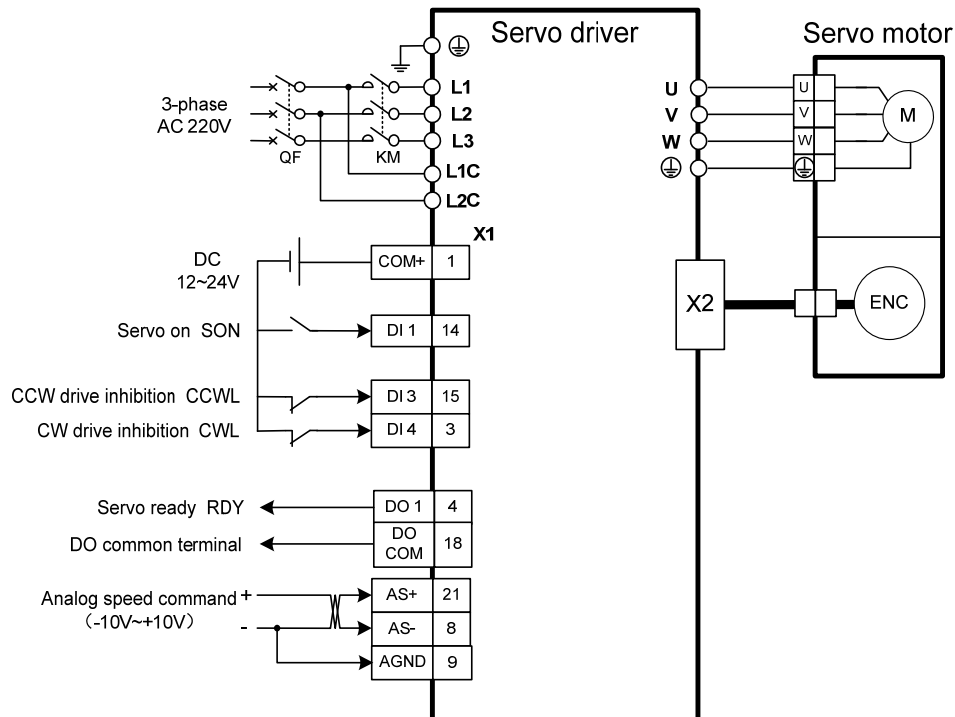

Example parameter settings:

Parameter	Name	Setting value	Default value	Parameter explanation
P004	Control mode	2	0	Set for torque control.
P026	Torque command source	0	0	Set for analog input.
P097	Ignore drive inhibit	3	3	Use forward drive inhibit (CCWL) and reverse drive inhibit (CWL). If set to ignore, did not connect CCWL、CWL.
P100	Digital input DI1 function	1	1	DI1 is set to servo enable SON
P130	Digital output DO1 function	2	2	DO1 is set to servo ready RDY

4.4.2 Parameters related to torque command

The following table shows the parameters related to torque command:

Parameter	Name	Range	Default value	Unit	Usage
P026	Torque command source	0~2	0		T
P053	Analog torque command gain	1~300	30	%/V	T
P054	analog torque command zero offset compensation	-1500.0~1500.0	0.0	mv	T
P055	Analog torque command direction	0~1	0		T
P056	Analog torque command filter time constant	0.20~50.00	2.00	ms	T
P057	Analog torque command polarity	0~2	0		T

4.4.3 Torque command source

Torque command has several different sources, which are set by parameter P026:

P026	Explanation	Interpret
0	Torque command source	Ports AS+ and AS - input analog voltage
1	Internal torque command	It is determined by TRQ1 and TRQ2 inputted by DI [Note 1].
2	Analog torque command + Internal torque command	When TRQ1 and TRQ2 are OFF, it is an analog command, and the rest is determined by TRQ1 and TRQ2 [Note 2].

Note 1: Internal torque command:

DI Signals		Torque command
TRQ2	TRQ1	
0	0	Internal torque 1(parameterP145)
0	1	Internal torque 2(parameterP146)
1	0	Internal torque 3(parameterP147)
1	1	Internal torque 4(parameterP148)

Note 2: Analog torque command + Internal torque command:

DI Signals		Torque command
TRQ2	TRQ1	
0	0	Analog torque command
0	1	Internal torque 2(parameterP146)
1	0	Internal torque 3(parameterP147)
1	1	Internal torque 4(parameterP148)

Above 0 indicates OFF; 1 indicates ON. Two DI inputs CZERO (zero command) and CINV (reverse command) can provide special functions. When CZERO is ON, the torque is forced to zero; When CINV is ON, the torque command is reversed.

4.4.4 Speed limit in torque control mode

In the torque control mode, the motor torque output is controlled by the command, but the motor speed is not controlled. Therefore, over-speed may occur under light load. In order to protect the machinery, the speed must be limited. The parameters related to speed limit are:

Parameter	Name	Range	Default value	Unit	Unit
P077	Speed limit selection	0~2	0		T
P078	Speed limit in torque control	0~5000	3000	r/min	T
P079	Speed limit error in torque control	1~5000	90	r/min	T

When over speed occurs, speed negative feedback is connected to reduce the actual torque, so as to reduce the actual speed, but the actual speed will be slightly higher than the speed limit value. The negative speed feedback is set by parameter P079. The smaller the value, the greater the negative feedback, the steeper the speed limit curve, and the smaller the over speed, but if it is too small, the jitter will become larger. There are three speed limits for torque control:

P077	Explanation	Interpret
0	Basic limit	Limited by parameter P078.
1	Basic limit +Analog limit	In addition to the basic limit, it is also limited by the analog speed command.
2	Basic limit +internal speed limit	In addition to the basic limit, it is also limited by the internal speed command, which is determined by the SP1, SP2 and SP3 input by DI.

Note: 1. Speed limit regardless of direction.

2. If many limits occur, the final limit value is the value with smaller absolute value.

3. Even if the set value exceeds the maximum speed allowed by the system, the actual speed will be limited to the maximum speed.

4. Internal speed command is determined by SP1, SP2 and SP3 input by DI:

Signal [Note]			Speed command
SP3	SP2	SP1	
0	0	0	Internal speed 1 (P137)
0	0	1	Internal speed 2 (P138)
0	1	0	Internal speed 13(P139)
0	1	1	Internal speed 4 (P140)
1	0	0	Internal speed 5 (P141)
1	0	1	Internal speed 6 (P142)
1	1	0	Internal speed 7 (P143)
1	1	1	Internal speed 8 (P144)

Note: 0 indicates OFF; 1 indicates ON.

4.5 Gain adjustment

Driver includes three control loops: current control loop, speed control loop and position control loop. The control block diagram is as follows:

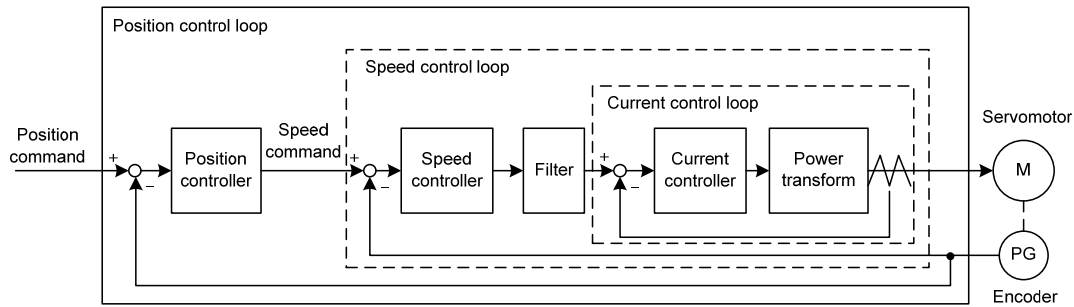

Theoretically, the bandwidth of the inner control loop must be higher than that of the outer control loop. Otherwise the whole control system will be unstable and cause vibration or poor response. Therefore, the relationship between the bandwidth of the three control loops is as follows:

Current loop bandwidth > speed loop bandwidth > position loop bandwidth

Since the driver has adjusted the current control loop to the best state, the user only needs to adjust the parameters of the speed control loop and the position control loop.

4.5.1 Gain parameters

Parameters related to gain are:

Parameter	Name	Range	Default value	Unit	Usage
P005	1st speed loop gain	1~3000	40	Hz	P,S
P006	1st speed loop integral time constant	1.0~1000.0	20.0	ms	P,S
P009	1st position loop gain	1~1000	40	1/s	P
P010	2nd speed loop gain	1~3000	40	Hz	P,S
P011	2nd speed loop integral time constant	1.0~1000.0	10.0	ms	P,S
P013	2nd position loop gain	1~1000	40	1/s	P
P017	Load moment of inertia ratio	0.0~200.0	1.0	times	P,S

Symbols are defined as follows:

K_v : Speed loop gain;

T_i : Speed loop integral time constant;

K_p : Position loop gain;

G: Load moment of inertia ratio (P017);

J_L : Load moment of inertia converted to motor shaft;

J_M : Moment of inertia of motor rotor.

1. Speed loop gain K_v

Speed loop gain K_v directly determines the response bandwidth of the speed loop. On the premise that the mechanical system does not produce vibration or noise, increasing the gain value of the speed loop will accelerate the speed response and the better the following of the speed command. However, excessive settings are easy to cause mechanical resonance. The bandwidth of the speed loop is expressed as:

$$\text{Speed loop bandwidth (Hz)} = \frac{1+G}{1+J_L/J_M} \times K_v \text{ (Hz)}$$

If the load moment of inertia ratio G is set correctly ($G=J_L/J_M$), the speed loop bandwidth is equal to the speed loop gain K_v .

2. Speed loop integral time constant T_i

Speed loop integration can effectively eliminate the steady-state error of speed and quickly respond to subtle speed changes. On the premise that the mechanical system does not produce vibration or noise, reduce the speed loop integral time constant T_i to increase the system rigidity and reduce the steady-state error. If the load inertia ratio is large or the mechanical system has resonance factors, it must be confirmed that the integral time constant of the speed loop is large enough. Otherwise the mechanical system is easy to produce resonance. If the load moment of inertia ratio G is set correctly ($G=J_L/J_M$), the speed loop integral time constant T_i is obtained by using the following formula:

$$T_i(ms) \geq \frac{4000}{2\pi \times K_v(Hz)}$$

3. Position loop gain K_p

Position loop gain directly determines the reaction speed of the position loop. On the premise that the mechanical system does not produce vibration or noise, increase the gain value of the position loop to speed up the reaction speed, reduce the position tracking error and shorten the positioning time. However, excessive setting will cause mechanical system jitter or positioning overshoot. The bandwidth of the position loop shall not be higher than that of the speed loop, generally

$$\text{Position loop bandwidth(Hz)} \leq \frac{\text{Speed loop bandwidth(Hz)}}{4}$$

If the load moment of inertia ratio G is set correctly ($G= J_L/J_M$), the position loop gain K_p is calculated as follows:

$$K_p(1/s) \leq 2\pi \times \frac{K_v(Hz)}{4}$$

4.5.2 Gain adjustment steps

The choice of position and speed bandwidth must be determined by the rigidity of the machine and the application of the conveyor belt connected by the low rigidity of the machine, can be set to lower frequency width; The mechanical stiffness of the ball screw driven by the reducer is medium and can be set to medium bandwidth; Direct drive ball screw or linear motor high stiffness, can be set to high frequency width. If the mechanical properties are unknown, increase the gain gradually to increase the bandwidth until resonance, and then lower the gain.

In servo gain, if one parameter is changed, other parameters need to be readjusted. Do not make major changes to just one parameter. Generally speaking, please follow the following principles when modifying servo parameters:

Increase response	Decrease response, restrain vibration and overshoot
1.Increase speed loop gain K_v	1.Decrease position loop gain K_p
2.Decrease speed loop integral time constant T_i	2.Increase speed loop integral time constant T_i
3.Increase position loop gain K_p	3.Decrease speed loop gain K_v

Speed control gain adjustment steps:

1. Set the load moment of inertia ratio.
2. Set the speed loop integral time constant to a larger value.
3. Increase the speed loop gain in the range without vibration and abnormal sound, and slightly decrease if vibration occurs.
4. Speed loop integral time constant should be reduced in the range without vibration, and slightly increased if vibration occurs.
5. If the gain cannot be increased due to resonance of the mechanical system and the desired responsiveness cannot be obtained, adjust the torque filter time constant (P007), and then repeat the

above steps to improve responsiveness.

Position control of the gain adjustment steps:

1. Set the load moment of inertia ratio.
2. Set the speed loop integration time constant to a larger value.
3. Increase the speed loop gain in the range without vibration and abnormal sound, and slightly decrease if vibration occurs.
4. Speed loop integration time constant should be reduced within the range without vibration, and slightly increased if vibration occurs.
5. Increase the position loop gain and slightly decrease the vibration if it occurs.
6. If the gain cannot be increased due to the resonance of the mechanical system and the desired responsiveness cannot be obtained, adjust the torque filter time constant (P007), and then repeat the above steps to improve responsiveness.
7. If shorter positioning time and smaller position tracking error are required, position feedforward can be adjusted appropriately, please refer to Section 4.2.4.

4.6 Resonance suppressions

When resonance occurs in the mechanical system, it may be caused by the servo system being too large and responding too fast. Reducing the gain may improve it. The driver provides a low-pass filter and a notch filter to suppress resonance without changing the gain. Parameters related to resonance suppression are as follows:

Parameter	Name	Range	Default value	Unit	Usage
P007	1st torque filter time constant	0.10~50.00	2.00	ms	ALL
P012	2nd torque filter time constant	0.01~50.00	1.00	ms	ALL
P200	1st resonant notch filter frequency	50~3000	1500	Hz	ALL
P201	1st notch filter quality factor	1~100	7		ALL
P202	1st notch filter depth	0~100	0	%	ALL
P203	2nd notch filter frequency	50~3000	1500	Hz	ALL
P204	2nd notch filter quality factor	1~100	7		ALL
P205	2nd notch filter depth	0~100	0	%	ALL

The principle of resonance suppression is to use a filter to suppress the formant of the mechanical response. The schematic diagram is as follows:

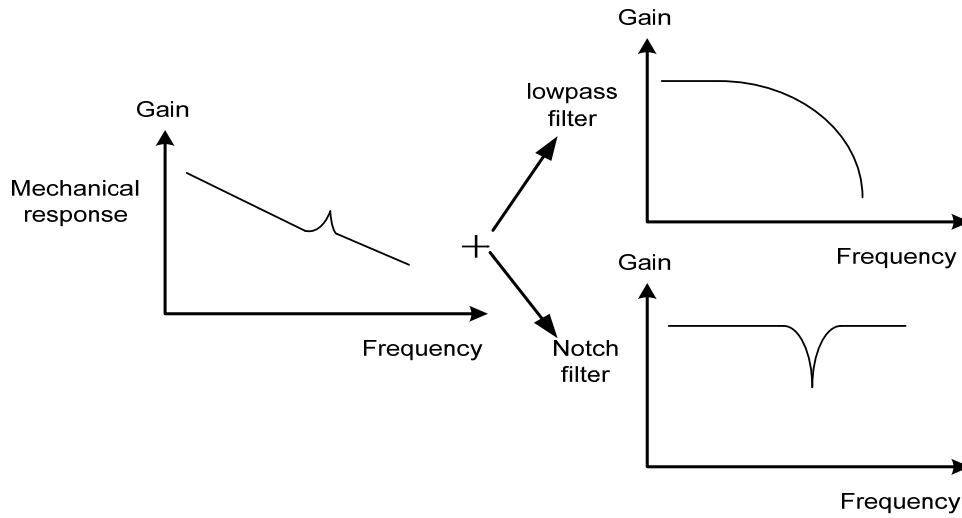

The characteristics of the two filters are:

Filter type	Suitable case	Advantage	Disadvantage
Low pass filter	High frequency resonance	Do not need to know the exact resonance frequency	Bring phase delay; reduce bandwidth of the system. Do not suitable for the case of medium and low frequency resonance.
Notch filters	Medium and low frequency resonance	Do not affect the bandwidth of the system.	It is important to know the exact resonance frequency. If make mistake of frequency setting, will affect the performance. It is not suitable that if the resonance frequency drifts all the time.

4.6.1 Low pass filters

Set by parameters P007 and P012, and select one of them for gain switching, which cannot be used at the same time. The low-pass filter is valid by default. Low pass filter has good attenuation to high frequency, and can better restrain high frequency resonance and noise. For example, when using a ball screw machine to improve the driver gain, high-frequency resonance sometimes occurs, and using a low-pass filter has a better effect. However, the system response bandwidth and phase margin are also reduced, and the system may become unstable. If the system is medium low frequency resonance, the low-pass filter cannot suppress it.

When the high frequency vibration of the machine is caused by the servo drive, adjust the time constant T_f of the torque filter. This may eliminate the vibration. The smaller the numerical value, the more responsive the control can be, but it is limited by mechanical conditions. The larger the value, the more high-frequency vibration can be suppressed. If the value is too large, the phase margin will be reduced, causing oscillation. If the load moment of inertia ratio G is set correctly ($G=J_L/J_M$), it shall meet the following requirements:

$$T_f (ms) \leq \frac{1000}{2\pi \times 2 \times K_v (Hz)}$$

4.6.2 Notch filters

Set by parameters P200~P205, two notch filters can be used at the same time to suppress two different frequency resonances. By default, both notch filters are turned off. If the resonance frequency can be known, the notch filter can directly eliminate the resonance. Generally, if the resonant frequency is determined, the notch filter is better than the low-pass filter. When the resonance frequency is unknown, the suppression frequency can be reduced gradually from high to low, and the suppression frequency at the minimum vibration point is the optimal setting value. However, if the resonance frequency shifts with time or other factors and the shift is too large, the notch filter is not suitable for use.

In addition to frequency, the notch depth and quality factor can also be adjusted, but pay attention to proper settings. The notch depth is deep, and the effect of mechanical resonance suppression may be good, but it will cause a large phase change, and sometimes it will strengthen the vibration. Small quality factor, wide notch width, mechanical resonance suppression may be very good, but it will cause large phase change area, sometimes it will strengthen the vibration.

4.7 Gains switching

Gain switching through internal state or external signal to achieve the following purposes:

- Switching to a lower gain when the motor stops (servo locking) to suppress vibration and sharp noise;
- Switching to a higher gain when the motor stops to increase the rigidity of the servo;
- Switching to higher gain when the motor is running to obtain better command tracking performance and smaller positioning time;
- Switching different gains according to the load equipment to achieve the best control.

1st gain and the 2nd gain are combined forms, each group has four parameters, and they are switched at the same time. The following is the gain combination:

1st gain		2nd gain	
Para meter	Name	Para meter	Name
P005	1st speed loop gain	P010	2nd speed loop gain
P006	1st speed loop integral time constant	P011	2nd speed loop integral time constant
P007	1st torque filter time constant	P012	2nd torque filter time constant
P009	1st position loop gain	P013	2nd position loop gain

4.7.1 Gain switching parameters

Parameters related to gain switching are:

Para meter	Name	range	Default value	Unit	Usage
P208	Gain switching selection	0~5	0		ALL
P209	Gain switching level	0~32767	100		ALL
P210	Gain switching level hysteresis	0~32767	5		ALL
P211	Gain switching delay time	0~3000	5	ms	ALL
P212	Gain switching time	0~3000	5	ms	ALL

4.7.2 Gain switching action

Gain switching action conditions are:

P208	P209	Condition of gain switching
0	Unacted	Fixed 1st gain
1	Unacted	Fixed 2nd gain
2	Unacted	DI input GAIN terminal determines that OFF is the 1st gain and ON is the 2nd gain.
3	Frequency($\times 0.1$ kpps)	Input command pulse frequency exceeds P209 the switching condition is satisfied.
4	Position(pulse)	Pulse deviation exceeds P209, the switching conditions is satisfied
5	Speed (r/min)	Motor speed exceeds P209, the switching conditions is satisfied.

As shown in the figure below, when the switching conditions are satisfied, the gain is switched to the 2nd gain; when the switching conditions are unsatisfied, the gain is switches to the 1st gain. The change state of switching conditions must be maintained for more than the set time of parameter P211 before switching, so as to avoid false switching due to interference. When switching, the current gain combination will change linearly and smoothly to the target gain combination according to the setting time of parameter P212, and each parameter in the combination will change at the same time to avoid mechanical impact caused by sudden change of parameters. To prevent frequent switching, the comparator has a hysteresis (parameter P210).

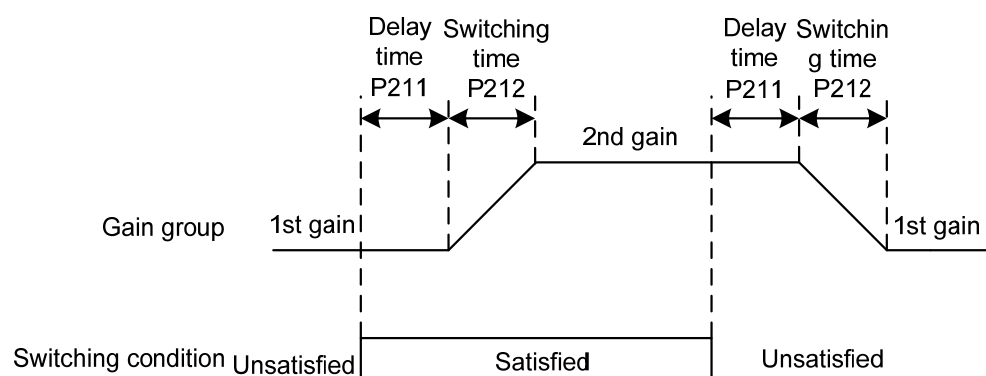

Speed PI/P control switching function can be realized. Set the 2nd speed loop integral time constant (P011) to the maximum (1000.0), which is equivalent to canceling the integration. Other parameters of the 2nd gain are the same as those of the 1st gain. As a result, the gain switching is equivalent to the speed PI/P control switching.

4.8 Homing

Homing is to let the machine move to a specified starting point as a reference home for future actions.

4.8.1 Homing parameters

The parameters related to homing are:

Parameter	Name	Range	Default value	Unit	Usage
P178	Homing trigger mode	0~3	0		ALL
P179	Homing reference point mode	0~6	0		ALL
P180	Homing mode	0~2	0		ALL
P181	Homing position offset high digit	-32768~32767	0	65536 pulse	ALL
P182	Homing position offset low digit	-32768~32767	0	pulse	ALL
P183	Homing first speed	1~3000	500	r/min	ALL
P184	Homing second speed	1~3000	50	r/min	ALL
P185	Homing acceleration time	0~30000	0	ms	ALL
P186	Homing deceleration time	0~30000	0	ms	ALL
P187	Homing in position delay time	0~3000	50	ms	ALL
P188	Homing completes signal delay	1~3000	100	ms	ALL
P189	Homing command execution mode	0~1	0		ALL

4.8.2 Homing operation steps

Homing operation in two steps:

1. Find reference point (Rough home)

After starting the homing function, find the reference point according to the homing first speed. You can use the input terminal REF (external detector input), CCWL or CWL as the reference point, or use the Z pulse as the reference point. You can select the forward or reverse direction to find.

2. Find home

After finding the reference point, search for home according to the home second speed. You can choose to continue to turn forward or backward to find the Z pulse, or you can directly use the reference point as home.

In the execution of homing, acceleration and deceleration can be set according to parameters P185 and P186 to prevent mechanical impact caused by rapid speed change. The found home plus the offset is used as the actual home. The offset is $P181 \times 65536 + P182$, the pulse here is a unified pulse unit, 65536 pulses per turn of the motor, and P181 parameter value is the number of turns of the motor.

4.8.3 Homing timing chart

1. Level trigger (P178=1)

After the SON is ON, the input terminal GOH triggers homing execution and suspends normal command execution. GOH is always ON. After homing is completed, the position and position deviation are cleared, and the output terminal HOME becomes ON. Until GOH becomes OFF, HOME becomes OFF.

When P189=0, execute the command after the HOME signal is turned OFF after the homing is completed. During the waiting period, the motor stays at home and does not accept the command; When P189=1, execute the command immediately after homing is completed.

If the servo enable SON is canceled, any alarm is generated, and GOH is turned OFF in advance during homing, the homing function is stopped and the output terminal HOME does not act.

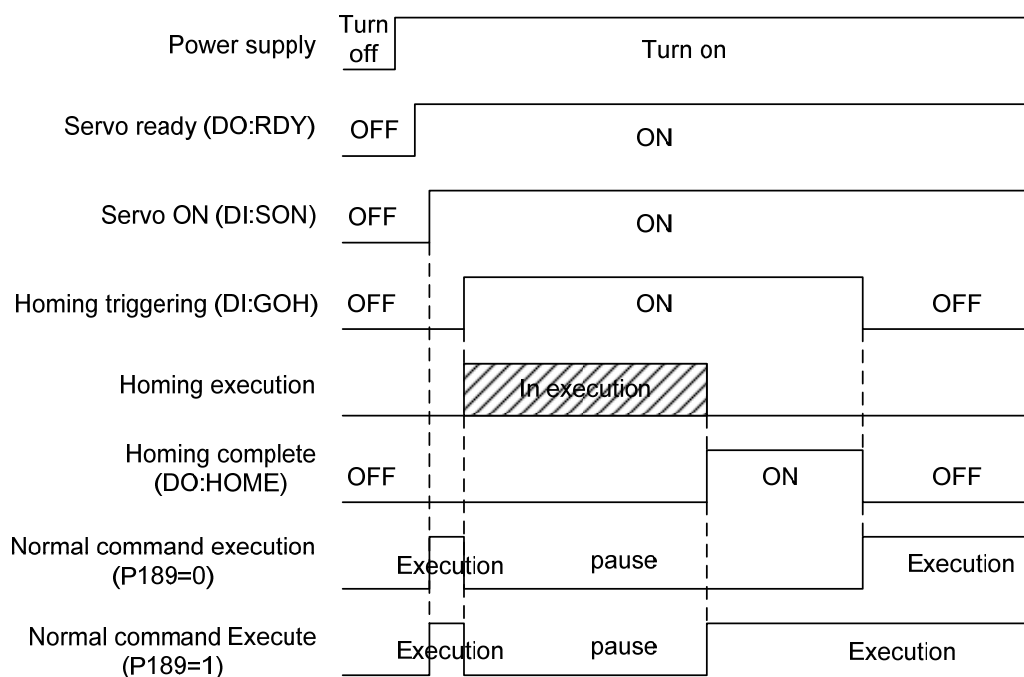

2. Rising edge trigger (P178=2)

After the SON is ON, the rising edge of the input terminal GOH triggers the homing execution and suspends the normal command execution. After homing is completed, the position and position deviation are cleared, and the output terminal HOME is turned ON. After the time delay P188 is set, HOME becomes OFF.

When P189=0, execute the command after the HOME signal is turned OFF after the homing is completed. During the waiting period, the motor stays at home and does not accept the command; When P189=1, execute the command immediately after homing is completed.

If the SON is OFF, any alarm is generated and GOH is turned OFF in advance during homing, the homing function is stopped and the output terminal HOME does not act.

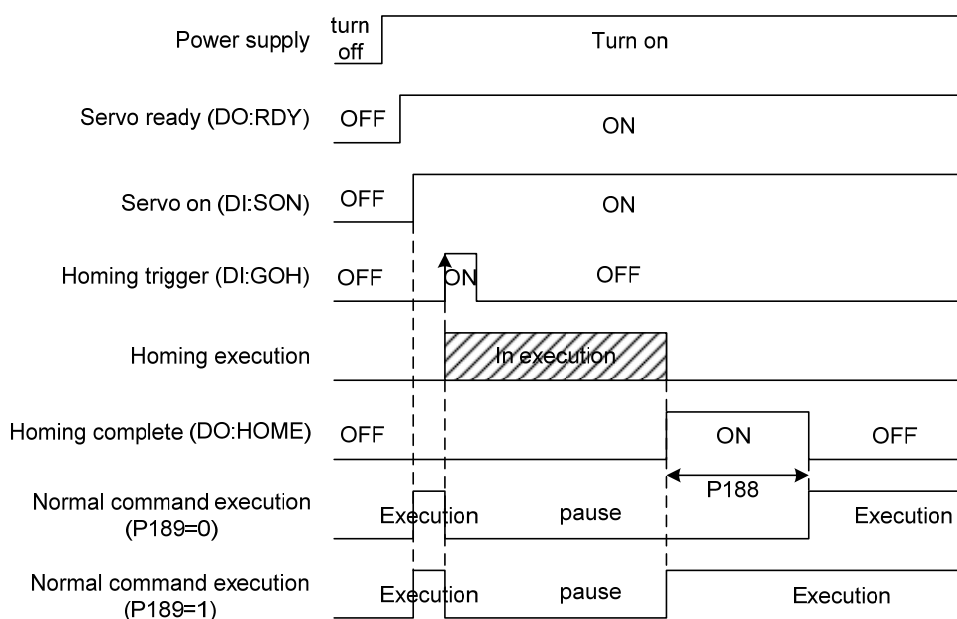

3. Turn on automatic execution (P178=3)

This function only uses in the condition that the power supply turn on and the SON is ON for the first time. Each time carries out homing operation once and will not need to execute homing operation later. Using this function can abbreviate a GOH input terminal.

After the homing completed, the position and the position deviation reset, the output signal of terminal HOME becomes ON. After the delay time set by P188 has completed, then HOME signal becomes OFF. Then can carry out the normal command execution again.

When P189=0, execute the command after the HOME signal is turned OFF after the homing is completed. During the waiting period, the motor stays at home and does not accept the command; When P189=1, execute the command immediately after homing is completed.

If the SON becomes OFF, or any alarm is generated during homing, the homing function is stopped and the output terminal HOME does not act. If the servo-on is not valid for the first time, homing cannot be triggered again.

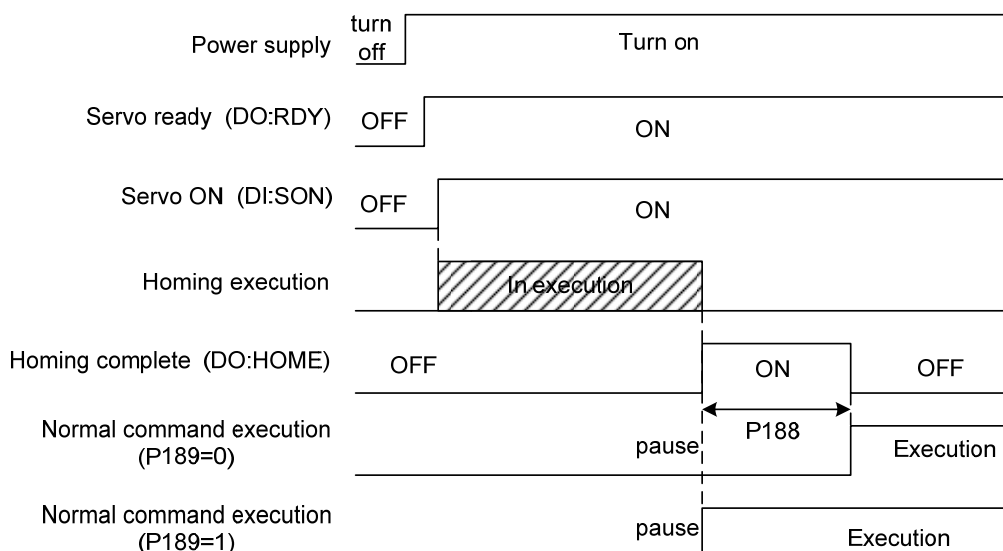

4.8.4 Homing combination mode timing chart

Homing reference point mode (P179) and homing mode (P180) have the following combinations.

(A) P179=0 or 2/P180=0

Parameter	Setting	Explanation
P179	0 or 2	After homing is started, find REF (rising edge trigger) or CCWL (falling edge trigger) as the reference point according to the homing first speed in CCW direction.
P180	0	After reaching the reference point, find the Z pulse as home according to the homing second speed in backward direction.

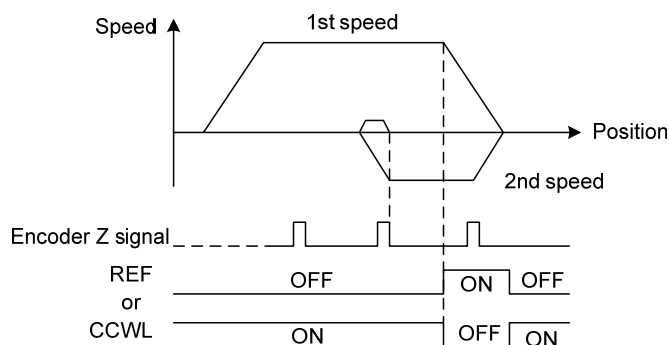

(B) P179=1 or 3/P180=0

Parameter	Setting	Explanation
P179	1 or 3	After homing is started, find REF (rising edge trigger) or CWL (falling edge trigger) as the reference point according to the homing first speed in CW direction.
P180	0	After reaching the reference point, find the Z pulse as home according to the homing second speed in backward direction.

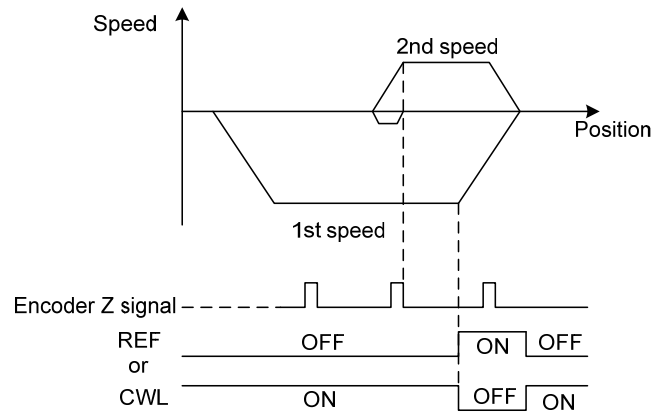

(C) P179=0/P180=1

Parameter	Setting	Explanation
P179	0	After homing is started, find REF (rising edge trigger) as the reference point according to the homing first speed in CCW direction.
P180	1	After reaching the reference point, find the Z pulse as home according to the homing second speed (P184) in the forward direction.

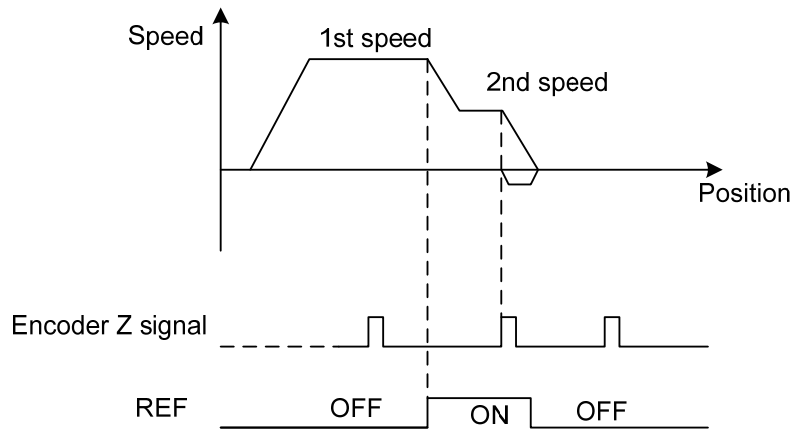

(D) P179=1/P180=1

Parameter	Setting	Explanation
P179	1	After homing starts, press home first speed reversal to find REF (rising edge trigger) as reference point.
P180	1	After reaching the reference point, find the Z pulse as home according to the homing second speed (P184) in the forward direction.

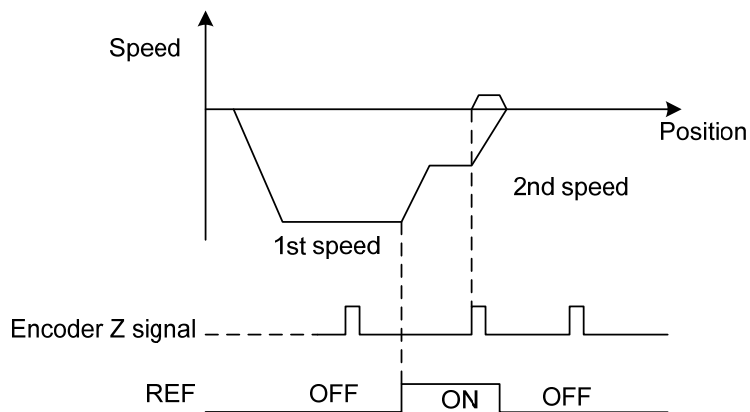
**(E) P179=0/P180=2**

Parameter	Setting	Explanation
P179	0	After homing is started, find REF (rising edge trigger) as the reference point according to the homing first speed in CCW direction.
P180	2	After reaching the reference point, the rising edge of the reference point is directly used as the home.

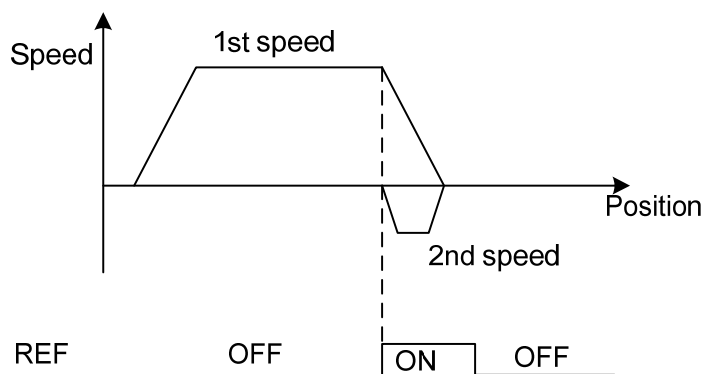

(F) P179=1/P180=2

Parameter	Setting	Explanation
P179	1	After homing is started, find REF (rising edge trigger) as the reference point according to the homing first speed in CW direction.
P180	2	After reaching the reference point, the rising edge of the reference point is directly used as the home.

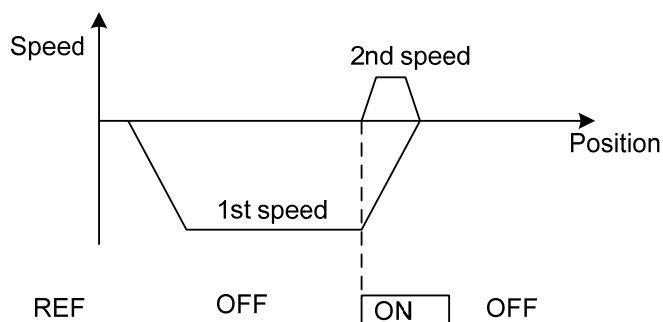

(G) P179=4/P180=2

Parameter	Setting	Explanation
P179	4	After homing is started, find the Z pulse as the reference point according to the homing first speed in CCW direction.
P180	2	After reaching the reference point, the rising edge of the reference point is directly used as the home.

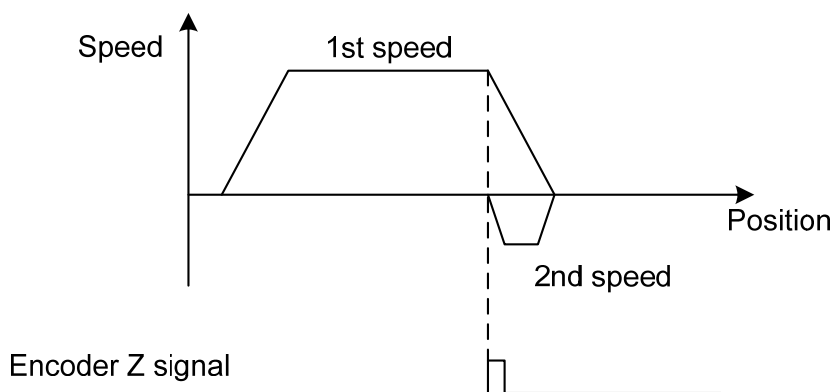

(H) P179=5/P180=2

Parameter	Setting	Explanation
P179	5	After homing is started, find the Z pulse as the reference point according to the homing first speed in CW direction.
P180	2	After reaching the reference point, the rising edge of the reference point is directly used as the home.

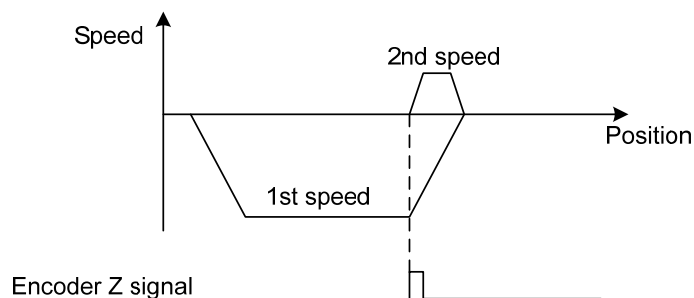
**(I) P179=6☆**

Parameter	Setting	Explanation
P179	6	After home is started, follow home first speed (P183) to approach home, and then return to home with home second speed (P184). (home is set by DI ZEROSET)

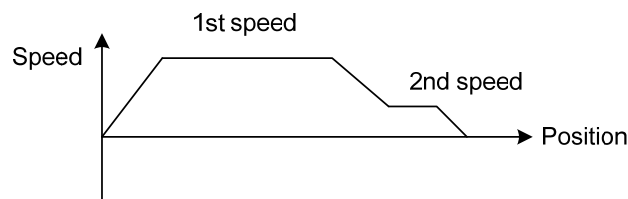

Conditions for using this mode:

- 1、 The driver model is EP1C Plus absolute value;
- 2、 The motor encoder is set to multi turn absolute value (P090=1);
- 3、 Home has been set with DI ZEROSET (default is 0).

4.9 Absolute value encoder setting☆

In this operating instructions, “☆” means the special function of absolute encoder. “★” means the special function of incremental encoder. For software versions above V13.49, the incremental encoder is canceled.

4.9.1 Absolute value encoder multi turn information backup☆

Absolute value encoder defaults to single turn absolute value. If the user needs multi turn position value, set parameter P090 to 1, save and restart the drive.

In order to save the multi turn position data of the absolute value encoder, a battery unit needs to be installed.

Signal input SD+, SD- (wire color is brown, brown and white), encoder power supply 0V、5V (wire color is black + black and white, red + red and white) are connected to the DB head, and the external battery pins E+、E- (wire color is yellow, yellow and white) are connected to the battery box.

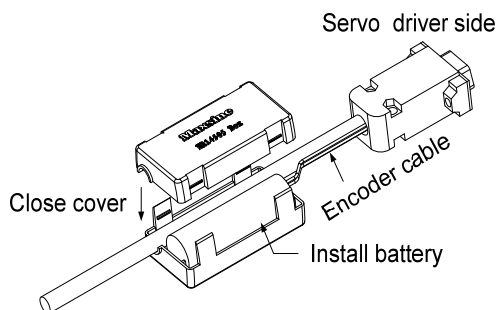

Note: Do not set the battery unit on both sides of the servo driver. Please set the battery unit on either side of the servo driver.

Battery voltage requirements: 3.2VDC~4.8VDC

When the battery voltage exceeds the range, the servo driver will give an alarm (Err48) when it is turned on. At this time, please replace the battery. **The battery needs to be replaced when the driver is turned on, otherwise the drive multi turn information will be initialized!** After replacing the battery, in order to remove the display of "Encoder battery alarm (Err48)", please ensure that the servo driver is not enabled. Connect the power supply of the servo driver control part and initialize the absolute encoder. After initialization, the multi turn value is 0. Confirm that the error display disappears and the servo driver can work normally.

4.9.2 Initialization of the absolute encoder☆

In the following cases, the absolute encoder must be initialized through Fn36. For details, please refer to Section 3.6.1.

- When the machine is initially started;
- When the rotation amount data of the absolute encoder is to be set to 0.

In the following cases, the encoder alarm must be cleared through Fn37. For details, please refer to Section 3.6.1.

- When "encoder battery alarm (Err48)" occurs;
- When "encoder internal fault alarm (Err41)" occurs.

4.10 Over-travel protection

Over-travel protection function refers to the safety function that the limit switch acts to force the motor to stop when the moving part of the machine exceeds the designed safe movement range. The diagram of over-travel protection is as follows:

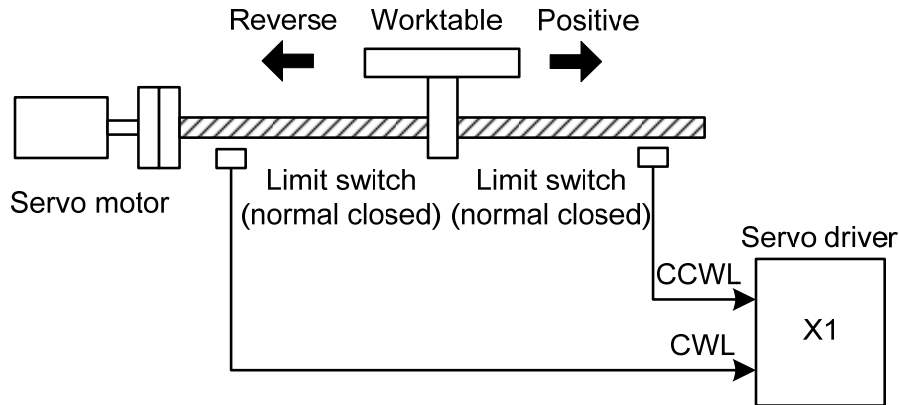

It is recommended to use the normally closed contact for the limit switch, which is closed within the safety range, and open if it is over-travel. Connected to forward drive inhibit (CCWL) and reverse drive inhibit (CWL), it can also be set to use and ignore through parameter P097. If it is set to use, the limit signal must be connected; set to ignore, the signal is not required. The default value of the parameter is that CCWL and CWL are ignored. If it needs to be used, the parameter P097 must be modified. Even in the over-travel state, it is still allowed to exit the over-travel state by inputting the reverse command.

P097	Reverse drive inhibit (CWL)	Forward drive inhibit (CCWL)
0	Use	Use
1	Use	Ignore
2	Ignore	Use
3(Default)	Ignore	Ignore

4.11 Torque limit

For the purpose of protecting machinery, the output torque can be limited.

4.11.1 Torque limit parameters

Parameters related to torque limit are:

Parameter	Name	Range	Default value	Unit	Usage
P064	Torque limit selection	0~2	0		ALL
P065	Internal torque limit in CCW direction	0~500	300	%	ALL
P066	Internal torque limit in CW direction	-500~0	-300	%	ALL
P067	External torque limit in CCW direction	0~500	100	%	ALL
P068	External torque limit in CW direction	-500~0	-100	%	ALL
P069	Torque limit in trial running	0~300	100	%	ALL

4.11.2 Torque limit mode

P064	Explanation	Forward (CCW)	Reverse (CW)
0	Basic limit	Determined by DI input TCCW: TCCW =OFF: parameter P065 TCCW =ON : parameter P067	Determined by DI input TCW: TCW =OFF: parameter P066 TCW =ON : parameter P068
1	Basic limit +analog limit	In addition to the basic limit, it is also limited by the analog torque command (this limit is regardless of directional).	
2	Basic limit +internal torque limit	In addition to the basic limit, it is also limited by the internal torque command (this limit is regardless of directional), which is determined by the TRQ1 and TRQ2 input by DI.	

Note: 1. If many limits occur, the final limit value is the value with smaller absolute value.

2. The limits of P065 and P066 are valid at any time.

3. Even if the setting value exceeds the maximum torque allowed by the system, the actual torque will be limited within the maximum torque.

The internal torque command is:

DI Signals[Note]		Torque command
TRQ2	TRQ1	
0	0	Internal torque 1 (P145)
0	1	Internal torque 2 (P146)
1	0	Internal torque 3 (P147)
1	1	Internal torque 4 (P148)

Note: 0 means OFF, 1 means ON.

4.12 Timing chart of operation

4.12.1 Timing chart when power supply switch on

- Control power supply L1C、L2C are turn on with the main power supply L1、L2、L3 at the same time or before the main circuit power supply. If only the power supply of the control circuit is turn on, the servo ready signal (RDY) is OFF.
- After the main power supply turn on, the delay is about 1.5 seconds, and the servo ready signal (RDY) is ON. At this time, the servo enable (SON) signal can be accepted. It is detected that the SON is effective, the power circuit is turned on, and the motor is excited, and it is in the running state. It is detected that the SON is invalid or there is an alarm, the power circuit is closed, and the motor is in a free state.

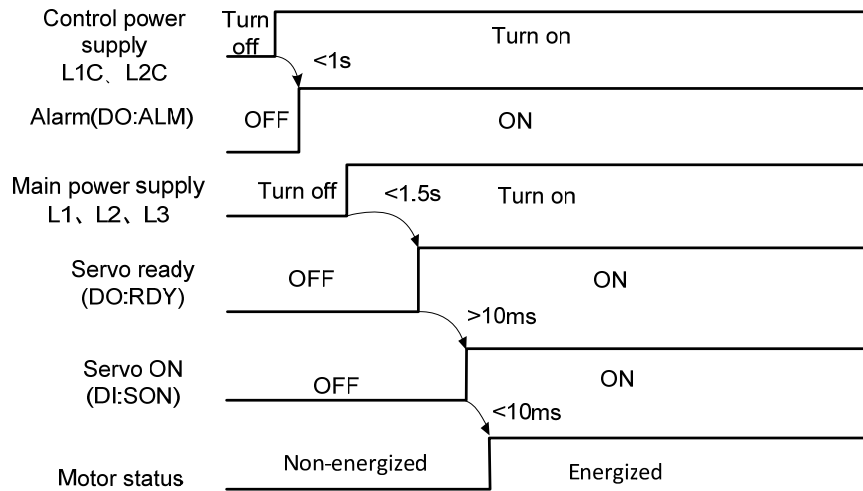

4.12.2 Alarm timing chart while servo-ON is executed

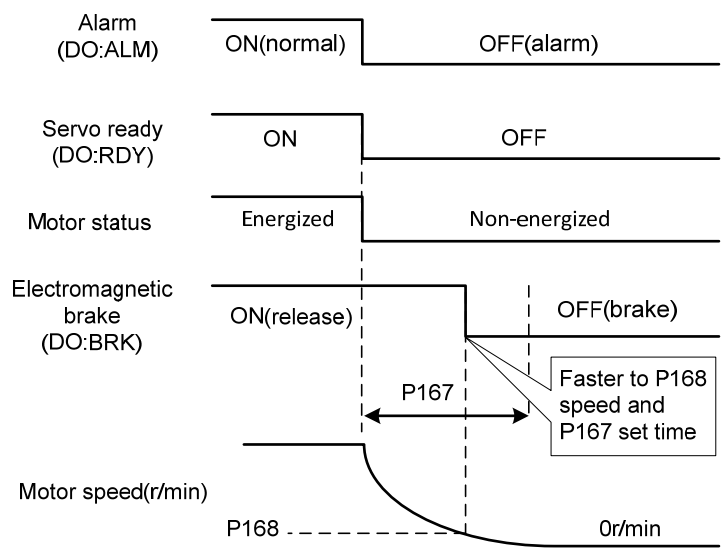

4.12.3 Servo ON/OFF action timing when the motor is stationary

When the motor speed is lower than parameter P165, the action-timing chart is:

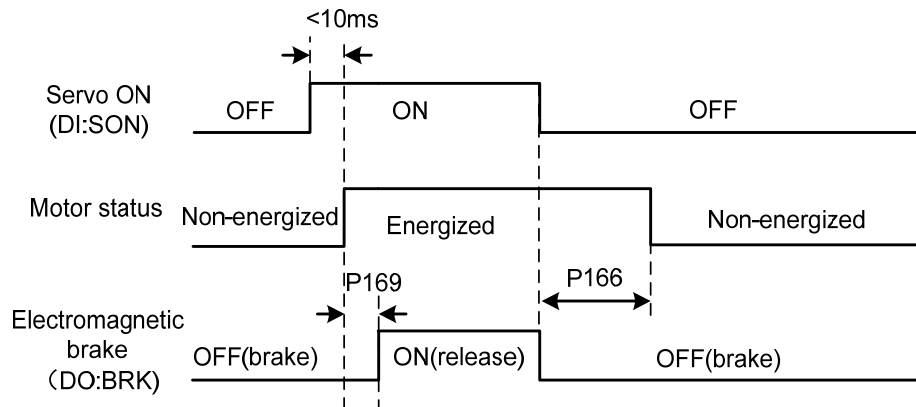

4.12.4 Servo ON/OFF action timing when the motor is running

When the motor speed is higher than parameter P165, the action-timing chart is:

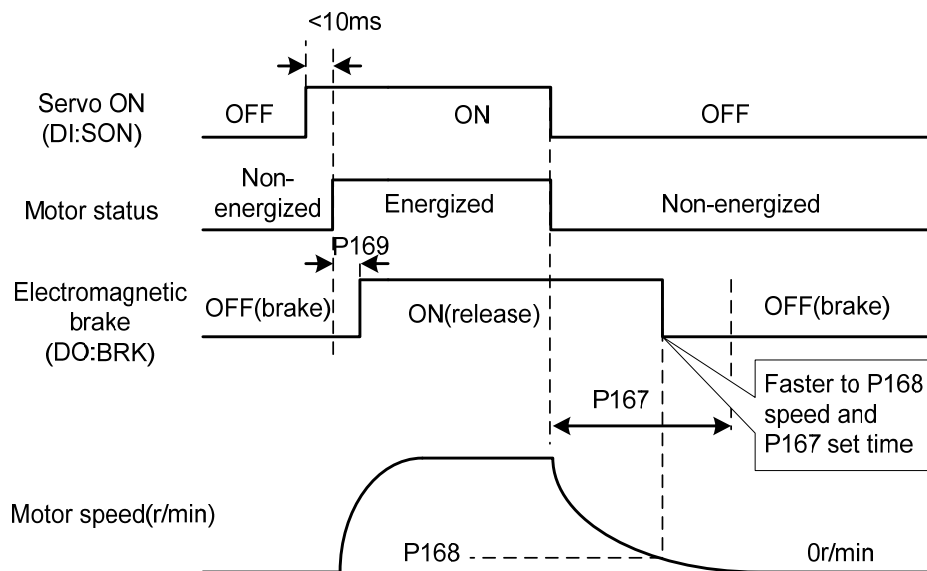

4.13 Electromagnetic brake

The electromagnetic brake (holding brake, lost power brake) is used in locking the vertical or the inclined worktable of machine tool, which connected with the motor. When the power supply lost or SON is OFF, prevent the worktable from fall and break. Realizes this function, must select and purchase the motor with electromagnetic brake. The brake only can use for holding the worktable and cannot use for decelerating and or stopping machine movement.

4.13.1 Electromagnetic brake parameter

Electromagnetic brake related parameters:

Parameter	Name	Range	Default value	Unit	Usage
P165	Motor static speed detection point	0~1000	5	r/min	ALL
P166	Electromagnetic brake delay time when the motor is stationary	0~2000	150	ms	ALL
P167	Waiting time of electromagnetic brake when the motor is running	0~2000	500	ms	ALL
P168	Action speed of electromagnetic brake when the motor is running	0~3000	100	r/min	ALL
P169	Delay time of electromagnetic brake opening	0~1000	0	ms	ALL

4.13.2 Use of electromagnetic brake

The following figure is the brake wiring diagram. The brake release signal BRK of the driver is connected to the relay coil. And the relay contact is connected to the brake power supply. The brake power supply is provided by the user and has sufficient capacity. It is recommended to install a surge absorber to suppress the surge voltage caused by the on/off action of the relay. Diodes can also be used as surge absorbers, which may cause a little braking delay.

After the motor stops stationary (speed is less than P165) and the servo is OFF. At this time, the motor continues to be turned on to maintain the position. The brake is released to brake. After a period of stability (the time is determined by parameter P166), remove the motor power supply.

When the motor changes from the non-enable state to the enable state, the delay time from the motor current opening to the electromagnetic brake release (DO output terminal BRK ON) is determined by parameter P169.

When the motor is running (speed is greater than P165), the servo is OFF. At this time, the motor current is cut off, and the brake continues to be released. After a period of delay, the brake is brake. This is to make the motor decelerate from high speed to low speed, and then make the mechanical brake act to avoid damage to the brake. The delay time is the minimum value of parameter P167 or the time required for the motor speed to decelerate to the speed of parameter P168.

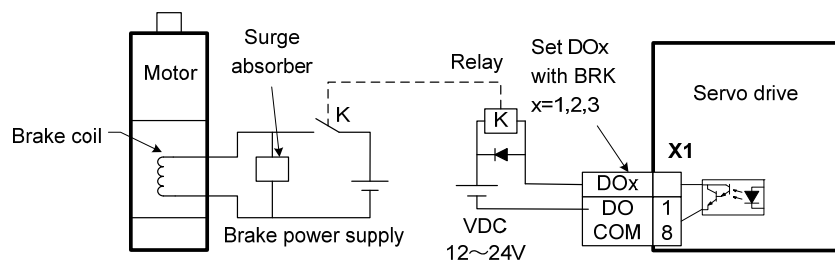

Chapter 5 Parameters

5.1 Parameter description in detail

The usage item in the table indicates the suitable control mode. “P” is the position control mode; “S” is the speed control mode; “T” is the torque control mode; “All” is the position, speed, and torque applicable. If the parameter value is “*”, the factory default value may be different.

In this operating instructions, “☆” means the special function of absolute encoder. “★” means the special function of incremental encoder. For software versions above V13.49, the incremental encoder is canceled.

5.1.1 Parameters of section 0

Parameter	Name	Range	Default value	Unit	Usage
P000	Password	0~9999	315		ALL

- Hierarchical parameter management can guarantee the parameters cannot modify by mistake.
- Setting this parameter as 315 can examine, modify the parameters of the 0、1、2 and 3 sections. For other setting only can examine, but cannot modify parameters.
- Some special operations need to set a suitable password.

Parameter	Name	Range	Default value	Unit	Usage
P001	Driver code	*	*		ALL

- The drive model currently in use. It has been set in the factory and cannot be modified by the user.

Parameter	Name	Range	Default value	Unit	Usage
P003	Software version	*	*		ALL

- The software version number cannot be modified.

Parameter	Name	Range	Default value	Unit	Usage
P004	Control mode	0~5	0		ALL

- Parameter meaning:

0: Position control mode	1: Speed control mode
2: Torque control mode	3: Position/speed control mode
4: Position/torque control mode	5: Speed/torque control mode
- When set to 3, 4, 5, the specific control mode is determined by the CMODE input by DI:

P004	CMODE[Note]	Control mode
3	0	Position control mode
	1	Speed control mode
4	0	Position control mode
	1	Torque control mode
5	0	Speed control mode
	1	Torque control mode

Note: 0 means OFF; 1 means ON.

Parameter	Name	Range	Default value	Unit	Usage
P005	1st speed loop gain	1~3000	40	Hz	P,S

- The proportional gain of the speed regulator can accelerate the speed response by increasing the parameter value. If it is too large, it is easy to cause vibration and noise.
- If P017 (moment of inertia ratio) is set correctly, the parameter value is equal to the speed response bandwidth.

Parameter	Name	Range	Default value	Unit	Usage
P006	1st speed loop integral time constant	1.0~1000.0	20.0	ms	P,S

- The integral time constant of the speed regulator can reduce the speed control error and increase the rigidity by reducing the parameter value. If it is too small, it is easy to cause vibration and noise.
- Setting to the maximum value (1000.0) means canceling integration, and the speed regulator is a P controller.

Parameter	Name	Range	Default value	Unit	Usage
P007	1st torque filter time constant	0.01~50.00	2.00	ms	ALL

- Torque low-pass filter can suppress mechanical vibration.
- The larger the value is, the better the vibration suppression effect will be. If the value is too large, the response will become slower, which may cause oscillation; the smaller the value, the faster the response, but limited by mechanical conditions.
- When the load inertia is small, a smaller value can be set; when the load inertia is large, a larger value can be set.

Parameter	Name	Range	Default value	Unit	Usage
P009	1st position loop gain	1~1000	40	1/s	P

- Proportional gain of position regulator; Increasing the parameter value can reduce the position tracking error and improve the response. Overshoot or oscillation may occur if the parameter value is too large.

Parameter	Name	Range	Default value	Unit	Usage
P010	2nd speed loop gain	1~3000	40	Hz	P,S

- Refer to the description of parameter P005. Only when the gain switching function is enabled, it needs to be set.

Parameter	Name	Range	Default value	Unit	Usage
P011	2nd speed loop integral time constant	1.0~1000.0	10.0	ms	P,S

- Refer to the description of parameter P006. Only when the gain switching function is enabled, it needs to be set.

Parameter	Name	Range	Default value	Unit	Usage
P012	2nd torque filter time constant	0.01~50.00	1.00	ms	ALL

- Refer to the description of parameter P007. Only when the gain switching function is enabled, it needs to be set.

Parameter	Name	Range	Default value	Unit	Usage
P013	2nd position loop gain	1~1000	80	1/s	P

- Refer to the description of parameter P009. Only when the gain switching function is enabled, it needs to be set.

Parameter	Name	Range	Default value	Unit	Usage
P017	Load moment of inertia ratio	0.0~200.0	1.0	times	P,S

- The ratio of the moment of inertia of a mechanical load (converted to the motor shaft) to the moment of inertia of the motor rotor.

Parameter	Name	Range	Default value	Unit	Usage
P018	Speed loop PDFF control coefficient	0~100	100	%	P,S

- For the PDFF coefficient of the speed regulator, the speed controller structure can be selected. 0 is the IP regulator, 100 is the PI regulator. And 1 ~ 99 is the PDFF regulator.
- If the parameter value is too large, the system will have high frequency response; if the parameter value is too small, the system will have high stiffness (resistance to deviation); if the parameter value is too small, both frequency response and stiffness will be considered.

Parameter	Name	Range	Default value	Unit	Usage
P019	Speed detection filter time constant	0.01~50.00	2.00	ms	P,S

- The larger the parameter value, the smoother the detection, the smaller the parameter value, the faster the detection response, too small may lead to noise; Too large can cause oscillation.

Parameter	Name	Range	Default value	Unit	Usage
P021	Position loop feed forward gain	0~100	0	%	P

- Feed forward can reduce the position tracking error in position control mode. When set to 100, the position tracking error is always 0 at any frequency of command pulse.
- When the parameter value increases, the position control response will be improved. If the parameter value is too large, the system will be unstable and easy to oscillate.

Parameter	Name	Range	Default value	Unit	Usage
P022	Position loop feed forward filter time constant	0.20~50.00	1.00	ms	P

- The function of filtering the feed forward of position loop is to increase the stability of feed forward control.

Parameter	Name	Range	Default value	Unit	Usage
P025	Speed command source	0~6	0		S

- In speed control mode, set the source of speed command.
- Parameter meaning:
0: Analog speed command come from terminal AS+ and AS- inputs.
1: Internal speed command is determined by SP1, SP2 and SP3 input by DI:

DI Signals[<i>note</i>]			Speed command
SP3	SP2	SP1	
0	0	0	Internal speed 1 (P137)
0	0	1	Internal speed 2 (P138)
0	1	0	Internal speed 3 (P139)
0	1	1	Internal speed 4 (P140)
1	0	0	Internal speed 5 (P141)
1	0	1	Internal speed 6 (P142)
1	1	0	Internal speed 7 (P143)
1	1	1	Internal speed 8 (P144)

Note: 0 indicates OFF; 1 indicates ON.

2: Analog speed command + internal speed command:

DI Signals[<i>note</i>]			Speed command
SP3	SP2	SP1	
0	0	0	Analog speed command
0	0	1	Internal speed 2 (P138)
0	1	0	Internal speed 3 (P139)
0	1	1	Internal speed 4 (P140)
1	0	0	Internal speed 5 (P141)
1	0	1	Internal speed 6 (P142)
1	1	0	Internal speed 7 (P143)
1	1	1	Internal speed 8 (P144)

Note: 0 indicates OFF; 1 indicates ON.

3: JOG speed command, which needs to be set during JOG operation.

4: Keyboard speed command, which needs to be set during keyboard speed adjustment (Sr) operation.

5: Demonstrate speed command. When speed regulation demonstration is carried out, it needs to be set, and the speed command will change automatically.

6: The speed command comes from the external pulse frequency.

Parameter	Name	Range	Default value	Unit	Usage
P026	Torque command source	0~2	0		T

● In torque control mode, set the source of torque command. Parameter meaning:

0: Analog torque command come from terminal AS+ and AS- inputs.

1: Internal torque command is determined by TRQ1 and TRQ2 from DI inputs.

DI Signals[<i>note</i>]		Torque command
TRQ2	TRQ1	
0	0	Internal torque 1 (P145)
0	1	Internal torque 2 (P146)
1	0	Internal torque 3 (P147)
1	1	Internal torque 4 (P148)

Note: 0 indicates OFF; 1 indicates ON.

2: Analog torque command + internal torque command:

DI Signal[<i>note</i>]		Torque command
TRQ2	TRQ1	
0	0	Analog torque command
0	1	Internal torque 2 (P146)
1	0	Internal torque 3 (P147)
1	1	Internal torque 4 (P148)

Note: 0 indicates OFF; 1 indicates ON.

Parameter	Name	Range	Default value	Unit	Usage
P027	Encoder pulse factor 1	1~32767	10000		P

- In position control, set the command pulse number needed by the motor rotating for one circle under the default circumstance (electronic gear ratio is 1:1)
The default value of P027 is 10000, and P028 is 1
 $PLUSE = P027 \times P028 = 10000 \times 1 = 10000$ means that the motor rotating for one circle needs 10000 command pulse when the electronic gear ratio is 1:1
- Users should ensure the result of $P027 \times P028$ is not more than 131072.

Parameter	Name	Range	Default value	Unit	Usage
P028	Encoder pulse factor 2	1~32767	1		P

- Encoder pulse factor 2, use the method of reference parameter P027 description.

Parameter	Name	Range	Default value	Unit	Usage
P029	1st numerator of command pulse electronic gear	1~32767	1		P
P030	Command pulse electronic gear denominator	1~32767	1		P
P031	2nd numerator of command pulse electronic gear	1~32767	1		P
P032	3rd numerator of command pulse electronic gear	1~32767	1		P
P033	4th numerator of command pulse electronic gear	1~32767	1		P

- Use the frequency division or multiplication for the input pulse and can conveniently match with each kind of pulse source, also can achieve the pulse resolution for the user needs.
- The electronic gear numerator N of command pulse is determined by GEAR1 and GEAR2 of the DI input. The denominator M is set by parameter P030.

DI Signals [note]		Command pulse electronic gear molecule N
GEAR2	GEAR1	
0	0	1 st numerator(P029)
0	1	2 nd numerator(P031)
1	0	3 rd numerator(P032)
1	1	4 th numerator(P033)

Note: 0 indicates OFF; 1 indicates ON.

- The input pulse command becomes the position command by the N/M factor. The ratio range is: $1/50 < N/M < 200$

Parameter	Name	Range	Default value	Unit	Usage
P035	Command pulse input mode	0~2	0		P

- Set the input mode of command pulse. Parameter Meaning:

- 0: Pulse + direction
- 1: Positive/Reverse pulse
- 2: Orthogonal pulse

Command pulse type	CCW	CW	Parameter P035
Pulse + direction	PULS SIGN	PULS SIGN	0
Positive/Reverse pulse	PULS SIGN	PULS SIGN	1
Orthogonal pulse	PULS SIGN	PULS SIGN	2

Note: The arrow indicates the counting edge when P036=0, P037=0.

● Command pulse input block diagram

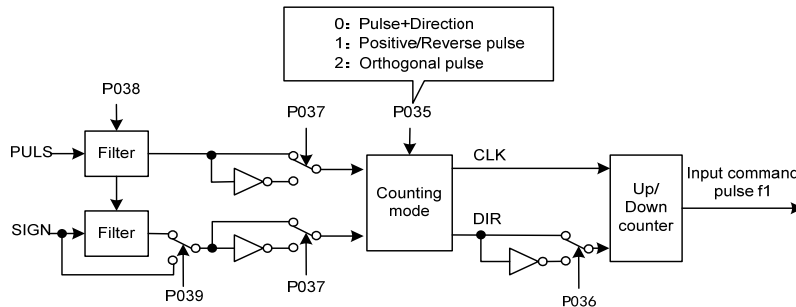

- After the parameter is modified, it must be saved and powered on again to be effective.

Parameter	Name	Range	Default value	Unit	Usage
P036	Command pulse input direction	0~1	0		P

- Parameter meaning:

0: Normal direction; 1: Reverse direction.

Parameter	Name	Range	Default value	Unit	Usage
P037	Command pulse input signal logic	0~3	0		P

- Set the pulse input signal PULS and SIGN signal phases to adjust the counting edge and counting direction.

P037	PULS signal phase	SIGN signal phase
0	In phase	In phase
1	Opposite phase	In phase
2	In phase	Opposite phase
3	Opposite phase	Opposite phase

- After the parameter is modified, it must be saved and powered on again to be effective.

Parameter	Name	Range	Default value	Unit	Usage
P038	Command pulse input signal filtering	0~21	0		P

- For digital filtering of pulse input signals PULS and SIGN, the larger the value, the larger the filtering time constant.
- By default, the maximum pulse input frequency is 500kHz (kpps). The larger the value, the lower the maximum pulse input frequency will be.
- It is used to filter the noise on the signal line and avoid counting errors. In case of inaccuracy caused by inaccurate counting, the parameter value can be increased appropriately.
- After the parameter is modified, it must be saved and powered on again to be effective.

Parameter	Name	Range	Default value	Unit	Usage
P039	Command pulse input filter mode	0~1	0		P

- Parameter meaning:
 - 0: Digital filtering of PULS and SIGN signals.
 - 1: Only PULS digital filtering, SIGN does not filter.
- After the parameter is modified, it must be saved and powered on again to be effective.

Parameter	Name	Range	Default value	Unit	Usage
P040	Position command exponential smoothing filter time	0~1000	0	ms	P

- The command pulse is smoothed and filtered with exponential acceleration and deceleration. The filter will not lose the input pulse, but the command delay will occur. When it is set to 0, the filter will not work.
- This filter is used to:
 1. The host controller has no acceleration and deceleration function;
 2. The electronic gear ratio is large ($N/M > 10$);
 3. The command frequency is low;
 4. When the motor is running, the phenomenon of step jumping and instability occurs.

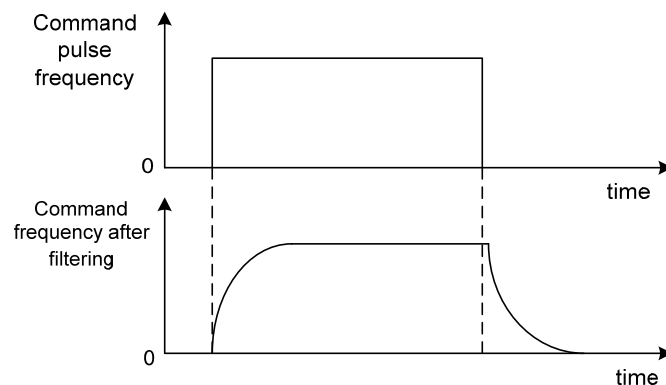

Parameter	Name	Range	Default value	Unit	Usage
P042	CWL,CCWL direction prohibited mode	0~1	0		P

- When the machine touches the mechanical limit switch and triggers CWL and CCWL limits, this parameter is used to select the prohibited mode.
- Parameter meaning:
 0: Limit the torque in this direction to 0.
 1: Pulse input in this direction is prohibited.

Parameter	Name	Range	Default value	Unit	Usage
P043	Select CWL, CCWL direction prohibited working function	0~1	0		P

- Parameter meaning:
 0: Normal mode, DI input CWL and CCWL play a limiting role.
 1: Set mode. When DI inputs CWL and CCWL, set the absolute value limit point of CWL and CCWL to P190~P193.

Parameter	Name	Range	Default value	Unit	Usage
P046	Analog speed command gain	10~3000	300	r/min/V	S

- Set the proportional relationship between the analog speed input voltage and the actual running speed of the motor.
- The analog input range is -10V~10V.

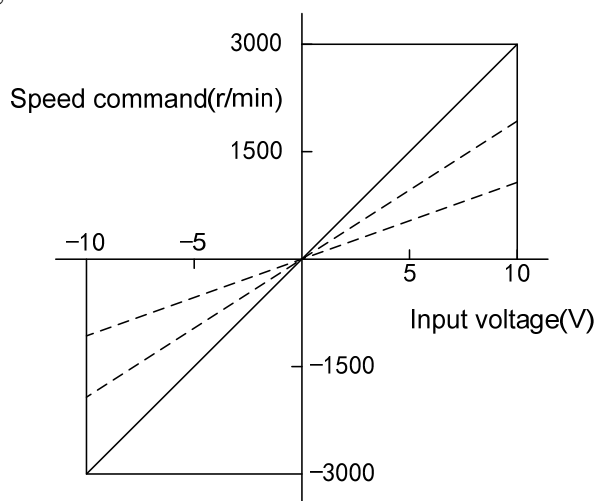

Parameter	Name	Range	Default value	Unit	Usage
P047	Analog speed command zero offset compensation	-1500.0~1500.0	0.0	mv	S

- Zero offset compensation of analog speed input. The actual speed command is the input analog

minus this parameter value.

- Automatic analog zero offset function can be used, and this parameter is automatically set, refer to Section 3.6.2.

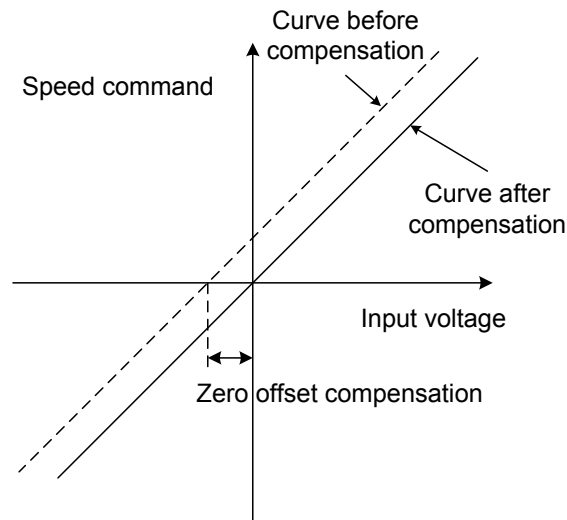

Parameter	Name	Range	Default value	Unit	Usage
P048	Analog speed command direction	0~1	0		S

- Parameter meaning::

P048	Positive polarity (positive voltage) analog input	Negative polarity (negative voltage) analog input
0	CCW speed command	CW speed command
1	CW speed command	CCW speed command

Parameter	Name	Range	Default value	Unit	Usage
P049	Analog speed command filter time constant	0.20~50.00	2.00	ms	S

- Low pass filter of analog speed input.
- The larger the setting, the slower the response speed of input analog quantity, which is conducive to reducing high-frequency noise interference; The smaller the setting is, the faster the response speed is, but the high-frequency noise interference is large.

Parameter	Name	Range	Default value	Unit	Usage
P050	Analog speed command polarity	0~2	0		S

- Parameter meaning:

0: Bipolarity.

1: Single positive polarity. Input positive polarity is valid, and negative polarity is forced to 0.

2: Single negative polarity. Negative input polarity is valid, and the positive polarity is forced to 0.

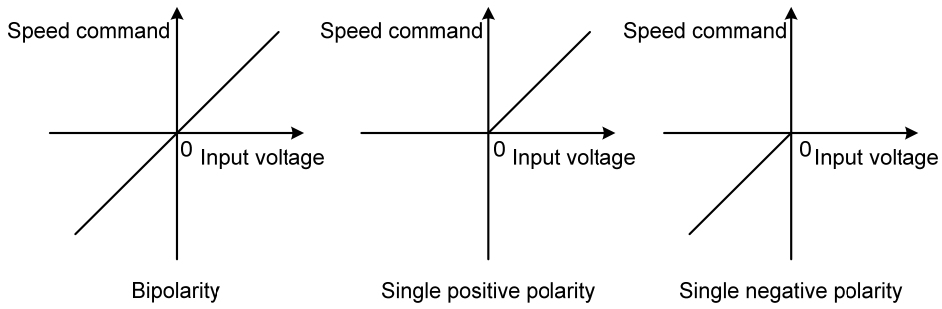

Parameter	Name	Range	Default value	Unit	Usage
P051	Analog speed command dead zone 1	0~13000	0	mv	S
P052	Analog speed command dead zone 2	-13000~0	0	mv	S

- When the input voltage is between dead zone 2(parameter P052) and dead zone 1(parameter P051), the command is forced to 0.

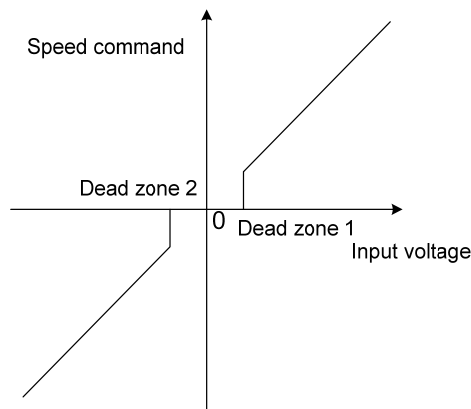

Parameter	Name	Range	Default value	Unit	Usage
P053	Analog torque command gain	1~300	30	%/V	T

- Set the proportional relationship between the analog torque input voltage and the actual running torque of the motor, and the unit of the set value is 1%/V;
- The analog input range is -10V~10V.

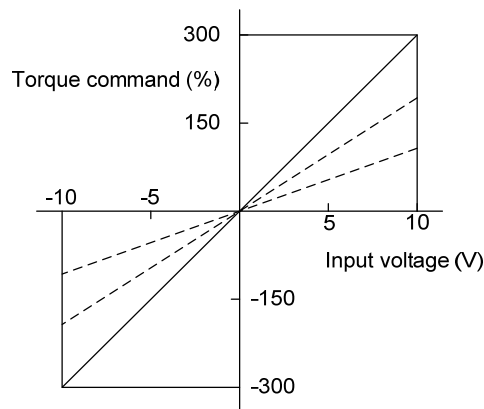

Parameter	Name	Range	Default value	Unit	Usage
P054	Analog torque command zero offset compensation	-1500.0~1500.0	0.0	mv	T

- Zero offset compensation of analog torque input. The actual torque command is the input analog minus this parameter value.
- Automatic analog quantity zero offset function can be used. This parameter is automatically set. Refer to Section 3.6.2.

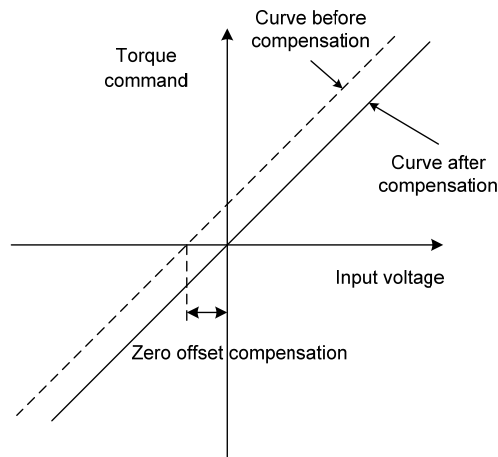

Parameter	Name	Range	Default value	Unit	Usage
P055	Analog torque command direction	0~1	0		T

- Parameter meaning::

P055	Positive polarity (positive voltage) analog input	Negative polarity (negative voltage) analog input
0	CCW torque command	CW torque command
1	CW torque command	CCW torque command

Parameter	Name	Range	Default value	Unit	Usage
P056	Analog torque command filter time constant	0.20~50.00	2.00	ms	T

- Analog torque input low pass filter.
- The larger the setting, the slower the response speed of input analog quantity, which is conducive to reducing high-frequency noise interference; The smaller the setting is, the faster the response speed is, but the high-frequency noise interference is large.

Parameter	Name	Range	Default value	Unit	Usage
P057	Analog torque command polarity	0~2	0		T

- Parameter meaning:
 0: Bipolarity.
 1: Single positive polarity. Input positive polarity is valid, and negative polarity is forced to 0.
 2: Single negative polarity. Negative input polarity is valid, and the positive polarity is forced to 0.

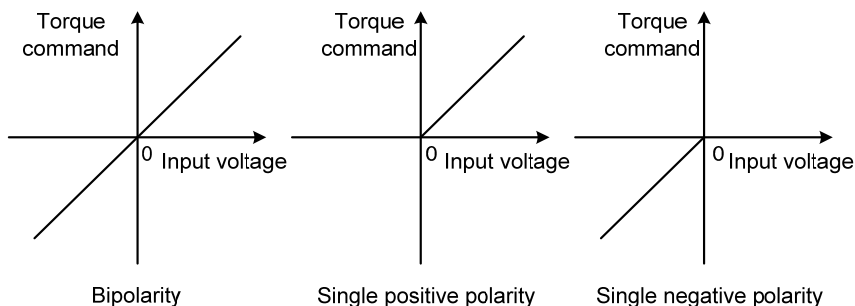

Parameter	Name	Range	Default value	Unit	Usage
P060	Speed command acceleration time	0~30000	0	ms	S

- Set the acceleration time of motor from zero speed to rated speed.
- If the command speed is lower than the rated speed, the required acceleration time will be reduced accordingly.
- Only for speed control mode, position control mode is invalid.
- If the drive and host device constitute position control, this parameter should be set to 0, otherwise the performance of position control will be affected.

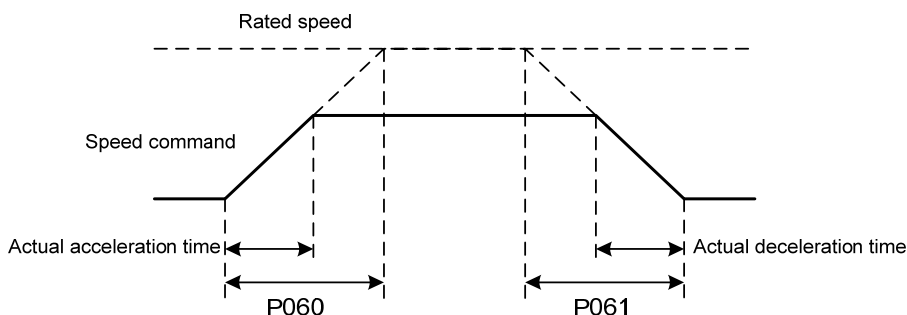

Parameter	Name	Range	Default value	Unit	Usage
P061	Speed command deceleration time	0~30000	0	ms	S

- Set the deceleration time of motor from rated speed to zero speed.
- If the command speed is lower than the rated speed, the deceleration time required will be reduced accordingly.
- Only for speed control mode, position control mode is invalid.
- If the driver is used in combination with the external position loop, this parameter should be set to 0. Otherwise the position control performance will be affected.

Parameter	Name	Range	Default value	Unit	Usage
P063	EMG(emergency shutdown) deceleration time	0~10000	1000	ms	ALL

- It works when the EMG (emergency shutdown) mode is deceleration stop (P164=1).
- Set the deceleration time of the EMG (emergency shutdown) motor from the current speed to zero speed.

Parameter	Name	Range	Default value	Unit	Usage
P064	Torque limit selection	0~2	0		ALL

- Set torque limit mode:

P064	Explanation	CCW	CW
0	Basic limit	Determined by DI input TCCW: TCCW =OFF: parameter P065 TCCW =ON : parameter P067	Determined by DI input TCW: TCW =OFF: parameter P066 TCW =ON : parameter P068
1	Basic limit + Analog limit	In addition to the basic limit, it is also limited by the analog torque command (this limit is regardless of direction).	
2	Basic limit + Internal torque limit	In addition to the basic limit, it is also limited by the internal torque command (this limit is regardless of direction), which is determined by the TRQ1 and TRQ2 input by DI.	

Note: 1. If many limits occur, the final limit value is the value with smaller absolute value.

2. The limits of P065 and P066 are valid at any time.

3. Even if the setting value exceeds the maximum torque allowed by the system, the actual torque will be limited within the maximum torque.

Parameter	Name	Range	Default value	Unit	Usage
P065	Internal torque limit in CCW direction	0~500	300	%	ALL
P066	Internal torque limit in CW direction	-500~0	-300	%	ALL

- This limit is valid at any time.
- If the set value exceeds the maximum overload capacity allowed by the system, the actual limit is the maximum overload capacity allowed by the system.

Parameter	Name	Range	Default value	Unit	Usage
P067	External torque limit in CCW direction	0~500	100	%	ALL
P068	External torque limit in CW direction	-500~0	-100	%	ALL

- When parameter P067 is DI input TCCW (torque limit in CCW direction) ON, this limit is valid.
- When parameter P068 is DI input TCW (torque limit in CW direction) ON, this limit is valid.
- When the limit is valid, the actual torque limit is the minimum of the maximum overload capacity, internal CCW torque limit and external CCW torque limit allowed by the system.

Parameter	Name	Range	Default value	Unit	Usage
P069	Torque limit in trial running	0~300	100	%	ALL

- Set the torque limit value for trial running mode (JOG running speed, keyboard speed adjustment, demonstration mode).
- Regardless of the direction of rotation, forward CCW and reverse CW are limited.
- The internal and external torque limits are still valid.

Parameter	Name	Range	Default value	Unit	Usage
P070	Forward (CCW) torque overload alarm level	0~300	300	%	ALL
P071	Reverse (CW) torque overload alarm level	-300~0	-300	%	ALL
P072	Torque overload alarm detection time	0~10000	0	10ms	ALL

- When the CCW torque of the motor exceeds P070 and the duration is greater than P072, the driver gives an alarm, the alarm number is Err29, and the motor stops.
- When the CW torque of the motor exceeds P071 and the duration is greater than P072, the driver gives an alarm, the alarm number is Err29, and the motor stops running.
- When parameter P072 is set to 0, the shielding torque overload alarm will occur.

Parameter	Name	Range	Default value	Unit	Usage
P075	Maximum speed limit	0~7200	5000	r/min	ALL

- Set the maximum allowable speed limit of the servo motor.
- Independent of the direction of rotation.
- If the set value exceeds the maximum speed allowed by the system, the actual speed will also be limited to the maximum speed.

Parameter	Name	Range	Default value	Unit	Usage
P076	JOG running speed	0~7500	100	r/min	S

- Set the running speed of JOG operation.

Parameter	Name	Range	Default value	Unit	Usage
P077	Speed limit selection	0~2	0		T

- Set the speed limit mode when torque control, and the speed limit is regardless of direction.

P077	Explanation	Interpret
0	Basic limit	Limited by parameter P078.
1	Basic limit +Analog limit	In addition to the basic limits, it is also limited by the analog speed command.
2	Basic limit + Internal speed limit	In addition to the basic limit, it is also limited by the internal speed command, which is determined by SP1, SP2 and SP3 input by DI. Refer to DI description.

Note: If many limits occur, the final limit value is the value with smaller absolute value. Even if the set value exceeds the maximum speed allowed by the system, the actual speed will be limited to the maximum speed.

Para meter	Name	Range	Default value	Unit	Usage
P078	Speed limit in torque control	0~5000	3000	r/min	T

- In the torque control mode, the motor running speed is limited within this parameter.
- It can prevent overspeed under light load.
- In case of overspeed, the speed negative feedback is connected to reduce the actual torque, but the actual speed will be slightly higher than the speed limit value.

Para meter	Name	Range	Default value	Unit	Usage
P079	Speed limit error in torque control	1~5000	90	r/min	T

- In case of overspeed, this parameter can adjust the speed negative feedback.
- The smaller the parameter value, the greater the negative feedback, the steeper the speed limit curve, and the smaller the overspeed, but too small may lead to jitter.

Para meter	Name	Range	Default value	Unit	Usage
P080	Position deviation limit	0.00~327.67	4.00	circle	P

- Set the position deviation alarm detection range.
- In the position control mode, when the count value of the position deviation counter exceeds the pulse corresponding to this parameter value, the servo driver gives a position deviation alarm (Err 4).
- The unit is circle. Multiply the resolution of each cycle of the encoder to obtain the number of pulses.

Para meter	Name	Range	Default value	Unit	Usage
P081 ~ P083	Recent alarm numbers 1~3	0~50	0		ALL

- Parameter meaning:
Keep the last 3 alarms.

Parameter	Name	Range	Default value	Unit	Usage
P084	Brake resistance selector switch	0~1	0		ALL

- Parameter meaning:
0: Adopting internal brake resistance.
1: Adopting external brake resistance.

Parameter	Name	Range	Default value	Unit	Usage
P085	Resistance value of external brake resistor	10~750	50	Ω	ALL

- Set this parameter according to the resistance value of the actual external brake resistor.
- If the internal brake resistor (P084=0) is used, this parameter is invalid.

Parameter	Name	Range	Default value	Unit	Usage
P086	Power of external brake resistor	10~10000	60	W	ALL

- This parameter is set according to the actual power of external brake resistor.
- If internal brake resistance (P084=0) is used, this parameter is invalid.

Parameter	Name	Range	Default value	Unit	Usage
P090	Absolute position encoder type (absolute type only)☆	0~1	0		ALL

- Parameter meaning:
0: Single turn absolute encoder.
1: Multi turn absolute encoder.
- When the encoder has no external battery, the encoder cannot save multi turn information. Please set this parameter to 0.

Parameter	Name	Range	Default value	Unit	Usage
P091	Different manufacturers read multiple code disk option	0~2	0		ALL

Parameter meaning:

- 0: Normal type.
- 1: New generation, when reading 90-92 parameters, the encoder information is returned.
- 2: Baoyuan, read 1010-1012 and return the encoder information.
- Note: When the parameter value is modified through ServoSoftStudio host software, due to customization by special manufacturers, the value can only be adjusted from 0 to 1 or from 0 to 2, and cannot be switched between 1 and 2 through the host software.

Parameter	Name	Range	Default value	Unit	Usage
P093	Fan alarm enable	0~1	1		ALL

- Parameter meaning:
0: Shield the fan fault alarm (except for special reasons, the customer is not recommended to shield

this bit).

1: Allow fan fault alarm.

Parameter	Name	Range	Default value	Unit	Usage
P094	Fan on temperature point	25~125	50	°C	ALL

- When the module temperature is higher than this temperature, the driver cooling fan starts to work.
- When the module temperature is lower than this temperature, the driver cooling fan stops working.
- When the module temperature is equal to 25 °C, the driver cooling fan will work all the time.

Parameter	Name	Range	Default value	Unit	Usage
P096	Initial display items	0~27	0		ALL

- Set the display status on the front panel after turn on the power supply. Parameter meaning:

P096	Display item	P096	Display item
0	Motor speed	14	Digital input DI
1	Initial position command	15	Digital output DO
2	Position command	16	Encoder signal
3	Motor position	17	Absolute position in one turn
4	Position deviation	18	Cumulative load rate
5	Torque	19	Braking load rate
6	Peak torque	20	Control mode
7	Current	21	Alarm number
8	Peak current	22	Reserved
9	Pulse input frequency	23	Load inertia ratio, reserved
10	Speed command	24	Bus voltage, reserved
11	Torque command	25	Motor ID number, reserved
12	Speed command analog voltage	26	Module internal temperature
13	Torque command analog voltage	27	Multi turn position

Parameter	Name	Range	Default value	Unit	Usage
P097	Ignore drive inhibit	0~3	3		ALL

- The forward drive inhibit (CCWL) and reverse drive inhibit (CWL) in DI input are used for limit travel protection. The normally closed switch is adopted. When the input is ON, the motor can run in this direction, and when it is OFF, it cannot run in this direction.
- If the limit travel protection is not used, it can be ignored through this parameter, so it can operate without connecting the driver inhibit signal.
- The default value is to ignore the drive inhibit. If you need to use the drive inhibit function, please modify this value first.
- Parameter meaning:

P097	Reverse drive inhibit (CWL)	Forward drive inhibit (CCWL)
0	Use	Use
1	Use	Ignore
2	Ignore	Use
3	Ignore	Ignore

Use: When the input signal is ON, the motor can run in this direction; When OFF, the motor cannot run to this side.

Ignore: The motor can run in this direction, and the drive inhibit signal has no effect, so the signal can not be connected.

Parameter	Name	Range	Default value	Unit	Usage
P098	Forced enable	0~1	0		ALL

- Parameter meaning::
 - 0: Enable the SON control input by DI;
 - 1: Software forced enable.

5.1.2 Parameters of section 1

Parameter	Name	Range	Default value	Unit	Usage
P100	Digital input DI1 function	-37~37	1		ALL
P101	Digital input DI2 function	-37~37	2		ALL
P102	Digital input DI3 function	-37~37	3		ALL
P103	Digital input DI4 function	-37~37	4		ALL
P104	Digital input DI5 function	-37~37	20		ALL

- Digital input DI function planning, parameter absolute value represents function, and symbol represents logic. Please refer to chapter 5.2 for functions.
- Symbols represent input logic, positive numbers represent positive logic, negative numbers represent negative logic, ON is valid, OFF is invalid:

Parameter	DI input signal	DI Result
Positive number	Turn off	OFF
	Turn on	ON
Negative number	Turn off	ON
	Turn on	OFF

- When multiple input channels have the same function selection, the function result is logic or relationship. For example, if both P100 and P101 are set to 1 (SON function), then SON is valid when either DI1 or DI2 is ON.
- If there is no input function selected by parameters P100~P104, that is, the function is not planned, the result is OFF (invalid). However, there are exceptions. Setting parameters P120~P124 can force the input function ON (valid), regardless of whether the function is planned or not.

Parameter	Name	Range	Default value	Unit	Usage
P110~P114	Digital input DI1~DI5 filtering	0.1~100.0	2.0	ms	ALL

- DI1 input digital filtering time constant.
- The smaller the parameter value, the faster the signal response speed. The larger the parameter value is, the slower the signal response speed is, but the stronger the noise filtering ability is.

Parameter	Name	Range	Default value	Unit	Usage
P120~P127	Digital input DI forced valid 1~8	00000~11111	00000		ALL

- P120 corresponding function by the 5-bit binary representation is as follows:

Bit number	bit4	bit3	bit2	bit1	bit0
Function	CWL	CCWL	ARST	SON	NULL

- P121 corresponding function by the 5-bit binary representation is as follows:

Bit number	bit4	bit3	bit2	bit1	bit0
Function	CINV	CZERO	ZCLAMP	TCW	TCCW

- P122 corresponding function by the 5-bit binary representation is as follows:

Bit number	bit4	bit3	bit2	bit1	bit0
Function	TRQ2	TRQ1	SP3	SP2	SP1

- P123 corresponding function by the 5-bit binary representation is as follows:

Bit number	bit4	bit3	bit2	bit1	bit0
Function	GEAR2	GEAR1	GAIN	CMODE	EMG

- P124 corresponding function by the 5-bit binary representation is as follows:

Bit number	bit4	bit3	bit2	bit1	bit0
Function	REF	GOH	PC	INH	CLR

- P125 corresponding function by the 5-bit binary representation is as follows:

Bit number	bit4	bit3	bit2	bit1	bit0
Function	NULL	NULL	NULL	NULL	NULL

- P126 corresponding function by the 5-bit binary representation is as follows:

Bit number	bit4	bit3	bit2	bit1	bit0
Function	NULL	NULL	NULL	NULL	NULL

- P127 corresponding function by the 5-bit binary representation is as follows:

Bit number	bit4	bit3	bit2	bit1	bit0
Function	NULL	NULL	ZERASET	NULL	NULL

- The function used to force DI input is valid. If the function corresponding bit is set to 1, the function is forced ON (valid).

- Refer to chapter 5.2 for the meaning of DI symbols.

- Parameter meaning:

A bit in this parameter	Function[<i>note</i>]	Function result
0	Not planned	OFF
	Planned	Determined by input signal
1	Not planned or planned	ON

Note: Planned refers to the function selected by parameters P100~P104.

Not planned refers to the function not selected by parameters P100~P104.

Parameter	Name	Range	Default value	Unit	Usage
P130	Digital output DO1 function	-16~16	2		ALL
P131	Digital output DO2 function	-16~16	3		ALL
P132	Digital output DO3 function	-16~16	8		ALL

- Digital output DO function planning, parameter absolute value represents function, and symbol represents logic. Please refer to chapter 5.3 for functions.

- 0 is forced OFF and 1 is forced ON.

- Symbols represent output logic, positive numbers represent positive logic, and negative numbers represent negative logic:

Parameter value	Function	DO output signal
Positive number	ON	Turn on
	OFF	Turn off
Negative number	ON	Turn off
	OFF	Turn on

Parameter	Name	Range	Default value	Unit	Usage
P137~P144	Internal speed 1~8	-5000~5000	0	r/min	S

- Refer to the description of parameter P025.

Parameter	Name	Range	Default value	Unit	Usage
P145~P148	Internal torque 1~4	-300.0~300.0	0.0	%	T

- Refer to the description of parameter P026.

Parameter	Name	Range	Default value	Unit	Usage
P150	Positioning completion range	0~32767	10	pulse	P
P151	Positioning completion hysteresis	0~32767	5	pulse	P

- Set the positioning completion pulse range in the position control mode.
- When the number of remaining pulses in the position deviation counter is less than or equal to the set value of this parameter, the COIN (positioning completion) of the digital output DO is ON, otherwise it is OFF.
- The comparator has the function of hysteresis, which is set by parameter P151.

Parameter	Name	Range	Default value	Unit	Usage
P152	Positioning approach range	0~32767	500	pulse	P
P153	Positioning approach hysteresis	0~32767	50	pulse	P

- Set the positioning approach pulse range in the position control mode.
- When the number of remaining pulses in the position deviation counter is less than or equal to the set value of this parameter, the NEAR of the digital output DO NEAR is ON, otherwise it is OFF.
- The comparator has the function of hysteresis, which is set by parameter P153.
- When the positioning is about to be completed, the host receives the NEAR signal to prepare for the next step. Generally, the parameter value should be greater than P150.

Parameter	Name	Range	Default value	Unit	Usage
P154	Arrival speed	-5000~5000	500	r/min	ALL
P155	Arrival speed hysteresis	0~5000	30	r/min	ALL
P156	Arrival speed polarity	0~1	0		ALL

- When the motor speed exceeds this parameter, the ASP (Arrival speed) of the digital output DO is ON, otherwise it is OFF.
- The comparator has the function of hysteresis, which is set by parameter P155.
- With polarity setting function:

P156	P154	Comparator
0	>0	detect CCW or CW speed
1	>0	Only detect CCW speed
	<0	Only detect CW speed

Parameter	Name	Range	Default value	Unit	Usage
P157	Arrival torque	-300~300	100	%	ALL
P158	Arrival torque hysteresis	0~300	5	%	ALL
P159	Arrival torque polarity	0~1	0		ALL

- When the motor torque exceeds this parameter, the ATRQ (Arrival torque) of the digital output DO is ON, otherwise it is OFF.
- The comparator has the function of hysteresis, which is set by parameter P158.
- With polarity setting function:

P159	P157	Comparator
0	>0	detect CCW or CW torque
1	>0	Only detect CCW torque
	<0	Only detect CW torque

Parameter	Name	Range	Default value	Unit	Usage
P160	Zero speed detection point	0~1000	10	r/min	ALL
P161	Zero speed detection hysteresis	0~1000	5	r/min	ALL

- When the motor speed is lower than this parameter, the ZSP (zero speed) of the digital output DO is ON, otherwise it is OFF.
- The comparator has the function of hysteresis, which is set by parameter P161.

Parameter	Name	Range	Default value	Unit	Usage
P162	Zero speed clamp mode	0~1	0		S

- When the following conditions are met, the zero speed clamping function is turned on:
 Condition 1: Speed control mode
 Condition 2: ZCLAMP (Zero Speed clamp) in DI is ON
 Condition 3: Speed command is lower than parameter P160
- When any of the above conditions is not met, the normal speed control is executed.
- When the zero speed clamping function is turned on, the meaning of this parameter is:
 0: The motor position is fixed at the moment when the function is turned on. At this time, the internal access position control will return to the zero fixed point even if it rotates due to external force.
 1: When the function is turned on, the speed command is forced to zero speed. The internal control is still speed control, which may rotate due to external forces.

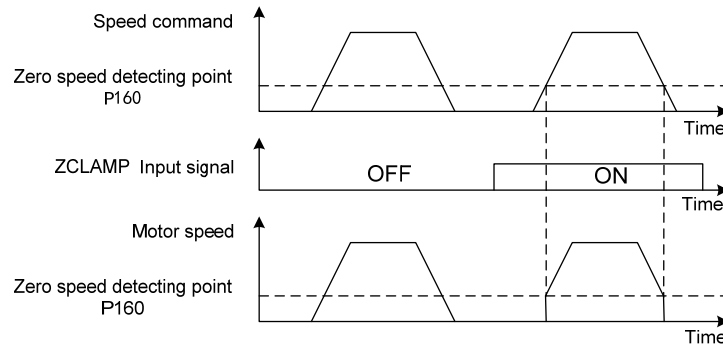

Parameter	Name	Range	Default value	Unit	Usage
P163	Position deviation clearing method	0~1	0		P

- In position control mode, clear the position deviation counter and use CLR (position deviation clearing) in DI.
- Parameter meaning, position deviation clearing occurs in:
 0: CLR ON level
 1: CLR rising edge (instant when OFF changes to ON)

Parameter	Name	Range	Default value	Unit	Usage
P164	Emergency shutdown mode	0~1	0		P

- When EMG (emergency shutdown) in DI is ON, the meaning of this parameter is:
 0: The driver turns off the motor current directly, and the motor stops freely;
 1: The driver remains enabled and controls the motor to decelerate and stop at the acceleration and deceleration time defined in P063.

Parameter	Name	Range	Default value	Unit	Usage
P165	Motor static speed detection point	0~1000	5	r/min	ALL

- Motor static detection: if the motor speed is lower than the parameter value, the motor is considered to be static.

- It is only used for timing judgment of electromagnetic brake.

Parameter	Name	Range	Default value	Unit	Usage
P166	Electromagnetic brake delay time when the motor is stationary	0~2000	150	ms	ALL

- When the SON of the servo driver is from ON go to OFF or an alarm occurs, define the delay time from electromagnetic brake braking (DO output terminal BRK OFF) to motor current turn off during motor standstill.
- This parameter enables the brake to turn off the current after reliable braking to avoid small displacement of the motor or work piece drop. The parameter shall not be less than the delay time of mechanical braking.
- Refer to chapter 4.12 for corresponding timing.

Parameter	Name	Range	Default value	Unit	Usage
P167	Waiting time of electromagnetic brake when motor is running	0~2000	500	ms	ALL
P168	Action speed of electromagnetic brake when motor is running	0~3000	100	r/min	ALL

- When the SON of the servo driver is from ON go to OFF or an alarm occurs, define the delay time from the motor current turn off to the electromagnetic brake braking (DO output terminal BRK OFF) during motor operation.
- This parameter is used to make the motor decelerate from high speed rotating state to low speed, and then let the brake braking to avoid damaging the brake.
- The actual action time is P167 or the time required for the motor to decelerate to P168, whichever is the minimum.
- Refer to chapter 4.12 for corresponding timing.

Parameter	Name	Range	Default value	Unit	Usage
P169	Delay time of electromagnetic brake opening	0~1000	0	ms	ALL

- When the SON of the servo driver is from OFF to ON, define the delay time from the motor current turn on to the electromagnetic brake release (DO output terminal BRK ON).
- Refer to chapter 4.12 for corresponding timing.

Parameter	Name	Range	Default value	Unit	Usage
P172	Encoder output lines	1~16384	2500		ALL

- Parameter meaning set parameters to determine the resolution of driver output pulse.
- The default value is 2500, which means that per revolution of the motor shaft, the output is $2500 \times 4 = 10000$ pulses.

Parameter	Name	Range	Default value	Unit	Usage
P173	Encoder outputs B pulse phase	0~1	0		ALL

- Parameter meaning:
0: In-phase
1: Reverse phase
- This parameter can adjust the phase relationship between B-phase signal and A-phase signal.

P173	CCW	CW
0	A phase lags B phase for 90 degree	A phase advances B phase for 90 degree
1	A phase advances B phase 90 degree	A phase lags B phase 90 degree

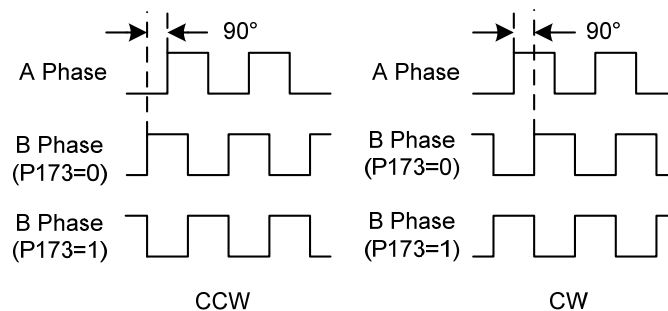

Parameter	Name	Range	Default value	Unit	Usage
P174	Encoder outputs Z pulse phase	0~1	0		ALL

- Parameter meaning:
0: In-phase;
1: Reverse phase

Parameter	Name	Range	Default value	Unit	Usage
P175	Encoder outputs Z pulse width	0~1	0		ALL

- Parameter meaning:
0: Width is the parameter value multiplied by 1 times the width of the output A (or B) signal;
1: Width is the parameter value multiplied by 4 times the width of the output A (or B) signal.
- Expand the Z pulse. When the host device cannot capture a narrow Z pulse, it can be widened. Note that it is best to use the leading edge of Z pulse.

Parameter	Name	Range	Default value	Unit	Usage
P176	Absolute value origin high value ☆	-32768~32767	0		ALL

- Only multi-turn absolute encoder is available.
- Absolute value origin position= $P176 * 216 + P177$.
- This bit is automatically filled in when DI input ZEROSET is triggered; or you can manually set the current position as the origin, and fill the high position of $d-RP\alpha$ into P176, and the low position into P177.

Parameter	Name	Range	Default value	Unit	Usage
P177	Absolute value origin low value ☆	-32768~32767	0		ALL

- Refer to P176 description.

Parameter	Name	Range	Default value	Unit	Usage
P178	Homing trigger mode	0~3	0		ALL

- Parameter meaning:
 - 0: Turn off the homing function
 - 1: Triggered by GOH level of DI input
 - 2: Triggered by GOH rising edge of DI input
 - 3: Turn on automatic execution
- Refer to chapter 4.8 for details.

Parameter	Name	Range	Default value	Unit	Usage
P179	Homing reference point mode ☆	0~6	0		ALL

- After homing starts, find the reference point according to the homing first speed (P183).
- Parameter meaning:
 - 0: Find REF (rising edge trigger) as reference point in CCW direction
 - 1: Find REF (rising edge trigger) as reference point in CW direction
 - 2: Find CCWL (falling edge trigger) as reference point in CCW direction
 - 3: Find CWL (falling edge trigger) as reference point in CW direction
 - 4: Find Z pulse as reference point in CCW direction
 - 5: Find Z pulse as reference point in CW direction
 - 6: Directly return to the DIZEROSET preset home, only valid for multi turn absolute encoder
- When setting CCWL or CWL as the reference point, the drive inhibit function is ignored when homing is executed, and the drive inhibit function is restored after homing is executed.
- Refer to chapter 4.8 for details.

Parameter	Name	Range	Default value	Unit	Usage
P180	Homing mode	0~2	0		ALL

- After reaching the reference point, find the home according to the homing second speed (P184).
- Parameter meaning:
 - 0: Find Z pulse backward as home
 - 1: Find Z pulse forward as home
 - 2: Directly use the rising edge of the reference point as the home
- Forward means that the second speed and the first speed are in the same direction, and backward means that the second speed and the first speed are in the opposite direction.

- Refer to chapter 4.8 for details.

Parameter	Name	Range	Default value	Unit	Usage
P181	Homing position offset high digit	-32768~32767	0	65536 pulse	ALL
P182	Homing position offset low digit	-32768~32767	0	pulse	ALL

- The found home plus the offset is used as the actual home. The offset is $P181 \times 65536 + P182$.

Parameter	Name	Range	Default value	Unit	Usage
P183	Homing first speed	1~3000	500	r/min	ALL

- In homing, find the reference point speed.

Parameter	Name	Range	Default value	Unit	Usage
P184	Homing second speed	1~3000	50	r/min	ALL

- In homing, after reaching the reference point, find the speed of home, which should be less than home first speed (P183).

Parameter	Name	Range	Default value	Unit	Usage
P185	Homing acceleration time	0~30000	0	ms	ALL

- Acceleration time of motor from zero speed to rated speed in homing execution.
- If the command speed is lower than the rated speed, the acceleration time required is also reduced accordingly.
- Only used in homing execution.

Parameter	Name	Range	Default value	Unit	Usage
P186	Homing deceleration time	0~30000	0	ms	ALL

- Deceleration time of motor from rated speed to zero speed in homing execution.
- If the initial command speed is lower than the rated speed, the required deceleration time is also shortened accordingly.
- Only used in homing execution.

Parameter	Name	Range	Default value	Unit	Usage
P187	Homing positioning delay time	0~3000	50	ms	ALL

- The delay time after reaching home stops the motor completely. After the delay is completed, DO output HOME changes to ON.

Parameter	Name	Range	Default value	Unit	Usage
P188	Homing completion signal delay	1~3000	100	ms	ALL

- For the case of P178=2 or 3, the effective time of HOME after homing is completed.

Parameter	Name	Range	Default value	Unit	Usage
P189	Homing command execution mode	0~1	0		ALL

- Parameter meaning:
0: After the homing is completed, wait for the HOME signal to turn OFF before executing the command.
1: Execute the command immediately after homing is completed.

Parameter	Name	Range	Default value	Unit	Usage
P190	CCW drive inhibit absolute high value ☆	-32768~32767	0		P

- Only multi turn absolute encoder is available. When using this soft limit function, P043 parameter should be set to 1.
- This bit is automatically filled in when DI input CCWL is triggered; or you can manually set the current position as the origin, and fill the high position of $d-RP_0$ into P190, and the low position into P191.

Parameter	Name	Range	Default value	Unit	Usage
P191	CCW drive inhibit absolute low value ☆	-32768~32767	0		P

- Refer to P190 parameter description.

Parameter	Name	Range	Default value	Unit	Usage
P192	CW drive inhibit absolute high value ☆	-32768~32767	0		P

- Only multi turn absolute encoder is available. When using this soft limit function, P043 parameter should be set to 1.
- This bit is automatically filled in when DI input CWL is triggered; or you can manually set the current position as the origin, and fill the high position of $d-RP_0$ into P192, and the low position into P193.

Parameter	Name	Range	Default value	Unit	Usage
P193	CW drive inhibit absolute low value ☆	-32768~32767	0		P

- Refer to P192 parameter description.

Parameter	Name	Range	Default value	Unit	Usage
P196	Absolute value initial position deviation ☆	0~32767	30		

- Absolute value is the initial position deviation of turn on. If it exceeds this range, it is judged that the encoder position has moved.

5.1.3 Parameters of section 2

Parameter	Name	Range	Default value	Unit	Usage
P200	1st notch filter frequency	50~3000	1500	Hz	ALL

- Notch filter is a filter used to eliminate the resonance of specific frequency caused by machinery.
- If parameter P202 is set to 0, this notch filter will be turned off.

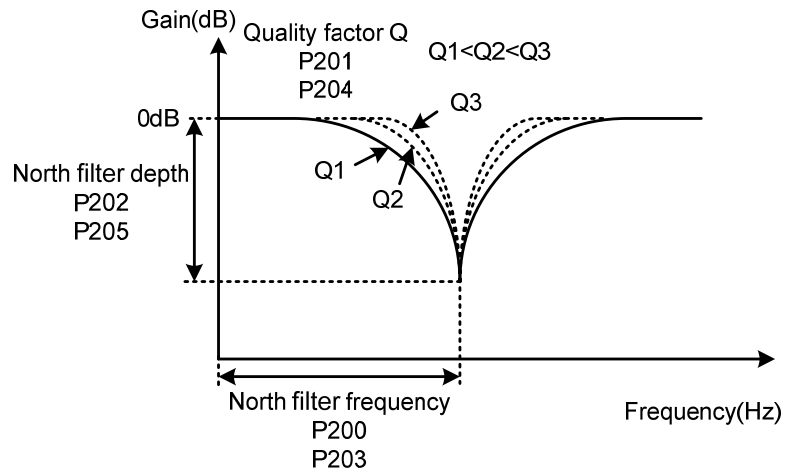

Parameter	Name	Range	Default value	Unit	Usage
P201	1st notch filter quality factor	1~100	7		ALL

- The quality factor Q indicates the notch filter shape. The larger the Q, the sharper the notch filter shape, and the narrower the notch filter width (- 3dB).

$$\text{Quality factor } Q = \frac{\text{North filter frequency}}{\text{North filter width}}$$

Parameter	Name	Range	Default value	Unit	Usage
P202	1st notch filter depth	0~100	0	%	ALL

- Set the notch depth of the notch filter. The larger the parameter, the greater the notch depth, that is, the greater the filter gain attenuation. Set to 0 to turn off the notch filter.
- Notch depth D expressed in dB units is:

$$D = -20 \log \left(1 - \frac{P202}{100} \right) (dB)$$

Parameter	Name	Range	Default value	Unit	Usage
P203	2nd notch filter frequency	50~3000	1500	Hz	ALL

- Notch filter is a filter used to eliminate specific frequency resonance caused by machinery.
- If P205 is set to 0, this notch filter will be turned off.

Parameter	Name	Range	Default value	Unit	Usage
P204	2nd notch filter quality factor	1~100	7		ALL

- Refer to the description of parameter P201.

Parameter	Name	Range	Default value	Unit	Usage
P205	2nd notch filter depth	0~100	0	%	ALL

- Set the notch depth of the notch filter. Setting it to 0 means turn off the notch filter. Refer to the explanation of parameter P202 for others.

Parameter	Name	Range	Default value	Unit	Usage
P208	Gain switching selection	0~5	0		ALL

- Parameter meaning:
 - 0: Fix the 1st gain.
 - 1: Fix the 2nd gain.
 - 2: DI input GAIN terminal control, OFF is the 1st gain, ON is the 2nd gain.
 - 3: Command pulse frequency control, switch to the 2nd gain when the input command pulse frequency exceeds P209.
 - 4: Pulse deviation control, switch to 2nd gain when the position pulse deviation exceeds P209.
 - 5: Motor speed control, switch to 2nd gain when the motor speed exceeds P209.
- The 1st gain and the 2nd gain are combined, with 4 parameters in each group and switching at the same time.

1st gain group		2nd gain group	
Parameter	Name	Parameter	Name
P005	1st speed loop gain	P010	2nd speed loop gain
P006	1st speed loop integral time constant	P011	2nd speed loop integration time constant
P007	1st torque filter time constant	P012	2nd torque filter time constant
P009	1st position loop gain	P013	2nd position loop gain

Parameter	Name	Range	Default value	Unit	Usage
P209	Gain switching level	0~32767	100		ALL
P210	Gain switching level hysteresis	0~32767	5		ALL

- According to the setting of parameter P208, the switching conditions and units are different.
- P210 is the same unit as P209.
- The comparator has the hysteresis function, which is set by parameter P210.

P208	Gain switching condition	unit
3	Command pulse frequency	0.1kHz(kpps)
4	Pulse deviation	pulse
5	Motor speed	r/min

Parameter	Name	Range	Default value	Unit	Usage
P211	Gain switching delay time	0~3000	5	ms	ALL

- The delay time from when the gain switching condition is satisfied to when the switching is started.
- Cancel the handover if it is detected that the handover condition is not satisfied in the delay phase.

Parameter	Name	Range	Default value	Unit	Usage
P212	Gain switching time	0~3000	5	ms	ALL

- During gain switching, the current gain combination will be linearly and smoothly transferred to the target gain combination in this time, and all parameters in the combination will change simultaneously.
- It can avoid impact caused by sudden change of parameters.

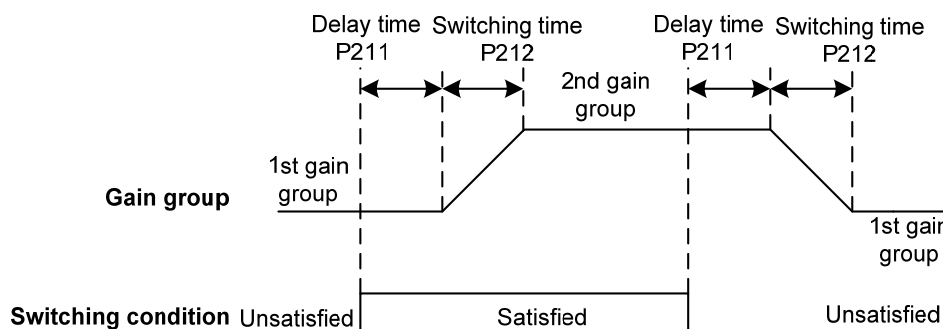

Parameter	Name	Range	Default value	Unit	Usage
P222	Compensation coefficient of vibration suppression	1.0~100.0	1.0		P

- Valid when the vibration suppression switch is turned on.
- The larger the value is, the more obvious the suppression effect is. However, too large a value is

likely to bring mechanical noise.

Parameter	Name	Range	Default value	Unit	Usage
P223	Vibration suppression mode	0~3	0		P

- Parameter meaning:
 - 0: Vibration suppression function is invalid
 - 1: Vibration suppression mode 1, which automatically detects vibration frequency, is suitable for occasions where inertia changes little.
 - 2: Vibration suppression mode 2, which automatically detects vibration frequency, is suitable for occasions where inertia always changes.
 - 3: Vibration suppression mode 3, manually set the vibration frequency, suitable for occasions where the vibration frequency is known.

Parameter	Name	Range	Default value	Unit	Usage
P224	Manually set the vibration period	0~1000	0	ms	P

- When the vibration suppression mode (P223) is set to 3, this parameter is used to set the vibration cycle to be suppressed.

Parameter	Name	Range	Default value	Unit	Usage
P226	Medium frequency vibration frequency	50~1500	100	Hz	P

- It is valid when the medium frequency vibration suppression switch is turned on (P229≠0).
- In the frequency point manual setting mode (P229=1), the medium frequency vibration point needs to be found through the FFT function of the servo host software.

This parameter is valid for software version V12.22/V13.22 or above.

Parameter	Name	Range	Default value	Unit	Usage
P227	Compensation coefficient of medium frequency vibration suppression	1~1000	100	%	P

- It is recommended to use the Fn1 function to estimate the load inertia first.
- If the servo inertia (P017) is set properly, it is recommended to set this parameter to 100.
- If the inertia cannot be estimated, the value is inversely proportional to the actual load inertia.

This parameter is valid for software version V12.22/V13.22 or above.

Parameter	Name	Range	Default value	Unit	Usage
P228	Damping coefficient of medium frequency vibration suppression	0~300	0	%	P

- Increasing the damping coefficient can improve the anti vibration effect, but excessive damping coefficient will increase the vibration.

This parameter is valid for software version V12.22/V13.22 or above.

Parameter	Name	Range	Default value	Unit	Usage
P229	Medium frequency vibration suppression switch	0~2	0		P

- Parameter meaning:

- 0: Invalid

- 1: Valid

- 2: Automatic setting

- This parameter is valid for software version V12.22/V13.22 or above.

5.1.4 Parameters of section 3

Parameter	Name	Range	Default value	Unit	Usage
P300	Drive ID number	1~32	1		M

- Drive ID number is a parameter used to set the MODBUS communication station number.
- If MODBUS communication is used, the communication address of the servo driver shall be set with different servo driver station numbers based on this parameter. The setting range of station numbers is 1~32. One group of servo drivers can only set one station number. Repeated setting of station numbers will lead to failure of normal communication.

Parameter	Name	Range	Default value	Unit	Usage
P301	MODBUS communication baud rate	0~6	0		M

- Set MODBUS communication baud rate
- Parameter meaning: (unit: bit/s)
 - 0: MODBUS mode prohibition, USB communication enabled
 - 1: Baud rate is 4800
 - 2: Baud rate is 9600
 - 3: Baud rate is 19200
 - 4: Baud rate is 38400
 - 5: Baud rate is 57600
 - 6: Baud rate is 115200

Parameter	Name	Range	Default value	Unit	Usage
P302	MODBUS communication protocol selection	0~5	4		M

- Select the communication protocol of MODBUS through this parameter. The selected communication protocol shall be consistent with the communication protocol of host controller. The specific setting value is as follows, and the initial value is 4.
- Parameter meaning:
 - 0: 8, N, 1 (MODBUS, ASCII)
 - 1: 8, E, 1 (MODBUS, ASCII)
 - 2: 8, O, 1 (MODBUS, ASCII)
 - 3: 8, N, 1 (MODBUS, RTU)
 - 4: 8, E, 1 (MODBUS, RTU)
 - 5: 8, O, 1 (MODBUS, RTU)
- Parameter details:

Numeral 8 represents that the transmitted data bits are 8 bits; The English letters N, E and O represent parity bits, N represents not using this bit, E represents 1 even bit, and O represents 1 odd bit; Numeral 1 indicates that there is one end bit.

Parameter	Name	Range	Default value	Unit	Usage
P303	Type of CAN bus	0~1	0		P

- Parameter meaning:
 - 0: Slave station
 - 1: Main station

5.2 DI function details

Ordinal	Symbol	DI Function	Functional explanation														
0	NULL	No function	Input state had no effect on the system.														
1	SON	Servo enable	OFF: Servo driver is not enabled and the motor is not energized; ON: Servo driver is enabled and the motor is energized.														
2	ARST	Clear alarm	When there is an alarm, if the alarm is allowed to be cleared, input the rising edge (OFF to ON moment) to clear the alarm. Note that only some alarms are allowed to be cleared.														
3	CCWL	CCW drive inhibit	<p>OFF: CCW rotation is prohibited; ON : CCW rotation is allowed.</p> <p>It is used for mechanical limit travel protection and its function is controlled by parameter P097. Note that the default value of P097 is to ignore this function. If you need to use this function, you need to modify P097.</p> <table border="1"> <thead> <tr> <th>P097</th> <th>Explanation</th> </tr> </thead> <tbody> <tr> <td>0</td> <td rowspan="2">To use the CCW drive inhibit function, the normally closed contact of the travel switch must be connected.</td> </tr> <tr> <td>2</td> </tr> <tr> <td>1</td> <td rowspan="2">Ignore the CCW drive inhibit function, the motor can run in the positive direction. This signal has no effect and does not need to be connected.</td> </tr> <tr> <td>3 (default)</td> </tr> </tbody> </table> <p>Inhibit mode:</p> <table border="1"> <thead> <tr> <th>P042</th> <th>Explanation</th> </tr> </thead> <tbody> <tr> <td>0</td> <td>In CCW drive inhibit function, CCW torque is limited as 0.</td> </tr> <tr> <td>1</td> <td>In CCW drive inhibit function, CCW pulse input is inhibited.</td> </tr> </tbody> </table>	P097	Explanation	0	To use the CCW drive inhibit function, the normally closed contact of the travel switch must be connected.	2	1	Ignore the CCW drive inhibit function, the motor can run in the positive direction. This signal has no effect and does not need to be connected.	3 (default)	P042	Explanation	0	In CCW drive inhibit function, CCW torque is limited as 0.	1	In CCW drive inhibit function, CCW pulse input is inhibited.
			P097	Explanation													
			0	To use the CCW drive inhibit function, the normally closed contact of the travel switch must be connected.													
			2														
			1	Ignore the CCW drive inhibit function, the motor can run in the positive direction. This signal has no effect and does not need to be connected.													
			3 (default)														
P042	Explanation																
0	In CCW drive inhibit function, CCW torque is limited as 0.																
1	In CCW drive inhibit function, CCW pulse input is inhibited.																
4	CWL	CW drive inhibit	<p>OFF: CCW rotation is prohibited; ON : CCW rotation is allowed.</p> <p>It is used for mechanical limit travel protection and its function is controlled by parameter P097. Note that the default value of P097 is to ignore this function. If you need to use this function, you need to modify P097.</p>														

Ordinal	Symbol	DI Function	Functional explanation								
4	CWL	CW drive inhibit	<table border="1"> <thead> <tr> <th>P097</th> <th>Explanation</th> </tr> </thead> <tbody> <tr> <td>0</td> <td rowspan="2">To use the CW drive inhibit function, the normally closed contact of the travel switch must be connected.</td> </tr> <tr> <td>2</td> </tr> <tr> <td>1</td> <td rowspan="2">Ignore the CW drive inhibit function, the motor can run in the positive direction. This signal has no effect and does not need to be connected.</td> </tr> <tr> <td>3 (default)</td> </tr> </tbody> </table>	P097	Explanation	0	To use the CW drive inhibit function, the normally closed contact of the travel switch must be connected.	2	1	Ignore the CW drive inhibit function, the motor can run in the positive direction. This signal has no effect and does not need to be connected.	3 (default)
			P097	Explanation							
			0	To use the CW drive inhibit function, the normally closed contact of the travel switch must be connected.							
			2								
			1	Ignore the CW drive inhibit function, the motor can run in the positive direction. This signal has no effect and does not need to be connected.							
			3 (default)								
Inhibit mode:											
<table border="1"> <thead> <tr> <th>P042</th> <th>Explanation</th> </tr> </thead> <tbody> <tr> <td>0</td> <td>In CW drive inhibit function, CW torque is limited as 0.</td> </tr> <tr> <td>1</td> <td>In CW drive inhibit function, CW pulse input is inhibited.</td> </tr> </tbody> </table>			P042	Explanation	0	In CW drive inhibit function, CW torque is limited as 0.	1	In CW drive inhibit function, CW pulse input is inhibited.			
P042	Explanation										
0	In CW drive inhibit function, CW torque is limited as 0.										
1	In CW drive inhibit function, CW pulse input is inhibited.										
5	TCCW	CCW torque limit	OFF: CCW direction torque is not limited by parameter P067; ON: CCW direction torque is limited by parameter P067. Note: Whether TCCW is valid or invalid, the torque in CCW direction is also limited by parameter P065.								
6	TCW	CW torque limit	OFF: CW direction torque is not limited by parameter P068; ON: CW direction torque is limited by parameter P068. Note: Whether TCW is valid or invalid, the torque in CW direction is also limited by parameter P066.								
7	ZCLAMP	Zero speed clamp	When the following conditions are met, the zero speed clamp function is enabled : Condition 1: speed control mode; Condition 2: ZCLAMP ON; Condition 3: Speed command is lower than parameter P160. If any of the above conditions are not met, normal speed control shall be performed. Refer to parameter P162 for specific application.								
8	CZERO	Zero command	In speed or torque control mode, speed or torque commands are: OFF: Normal command; ON: Zero command.								
9	CINV	Reverse command	In speed or torque control mode, speed or torque commands are: OFF: Normal command; ON: Reverse command.								

Ordinal	Symbol	DI Function	Functional explanation																																							
10	SP1	Internal speed selection 1	Speed control, speed limit, SP1, SP2, SP3 combination select internal speed 1 ~ 8: <table border="1" style="margin-left: 20px;"> <thead> <tr> <th colspan="3">DI signal[<i>note</i>]</th> <th rowspan="2">Speed command</th> </tr> <tr> <th>SP3</th> <th>SP2</th> <th>SP1</th> </tr> </thead> <tbody> <tr> <td>0</td> <td>0</td> <td>0</td> <td>Internal speed 1(parameter P137)</td> </tr> <tr> <td>0</td> <td>0</td> <td>1</td> <td>Internal speed 2(parameter P138)</td> </tr> <tr> <td>0</td> <td>1</td> <td>0</td> <td>Internal speed 3(parameter P139)</td> </tr> <tr> <td>0</td> <td>1</td> <td>1</td> <td>Internal speed 4(parameter P140)</td> </tr> <tr> <td>1</td> <td>0</td> <td>0</td> <td>Internal speed 5(parameter P141)</td> </tr> <tr> <td>1</td> <td>0</td> <td>1</td> <td>Internal speed 6(parameter P142)</td> </tr> <tr> <td>1</td> <td>1</td> <td>0</td> <td>Internal speed 7(parameter P143)</td> </tr> <tr> <td>1</td> <td>1</td> <td>1</td> <td>Internal speed 8(parameter P144)</td> </tr> </tbody> </table> <p style="text-align: center;"><i>Note:</i> 0 means OFF, 1 is ON.</p>	DI signal[<i>note</i>]			Speed command	SP3	SP2	SP1	0	0	0	Internal speed 1(parameter P137)	0	0	1	Internal speed 2(parameter P138)	0	1	0	Internal speed 3(parameter P139)	0	1	1	Internal speed 4(parameter P140)	1	0	0	Internal speed 5(parameter P141)	1	0	1	Internal speed 6(parameter P142)	1	1	0	Internal speed 7(parameter P143)	1	1	1	Internal speed 8(parameter P144)
DI signal[<i>note</i>]				Speed command																																						
SP3	SP2	SP1																																								
0	0	0		Internal speed 1(parameter P137)																																						
0	0	1		Internal speed 2(parameter P138)																																						
0	1	0		Internal speed 3(parameter P139)																																						
0	1	1		Internal speed 4(parameter P140)																																						
1	0	0		Internal speed 5(parameter P141)																																						
1	0	1		Internal speed 6(parameter P142)																																						
1	1	0		Internal speed 7(parameter P143)																																						
1	1	1	Internal speed 8(parameter P144)																																							
11	SP2	Internal speed selection 2																																								
12	SP3	Internal speed selection 3																																								
13	TRQ1	Internal torque selection 1	Torque control, torque limit, TRQ1, TRQ2 combination select internal torque 1~4: <table border="1" style="margin-left: 20px;"> <thead> <tr> <th colspan="2">DI signal[<i>note</i>]</th> <th rowspan="2">Torque command</th> </tr> <tr> <th>TRQ2</th> <th>TRQ1</th> </tr> </thead> <tbody> <tr> <td>0</td> <td>0</td> <td>Internal torque 1(parameter P145)</td> </tr> <tr> <td>0</td> <td>1</td> <td>Internal torque 2(parameter P146)</td> </tr> <tr> <td>1</td> <td>0</td> <td>Internal torque 3(parameter P147)</td> </tr> <tr> <td>1</td> <td>1</td> <td>Internal torque 4(parameter P148)</td> </tr> </tbody> </table> <p style="text-align: center;"><i>Note:</i> 0 means OFF, 1 is ON.</p>	DI signal[<i>note</i>]		Torque command	TRQ2	TRQ1	0	0	Internal torque 1(parameter P145)	0	1	Internal torque 2(parameter P146)	1	0	Internal torque 3(parameter P147)	1	1	Internal torque 4(parameter P148)																						
DI signal[<i>note</i>]		Torque command																																								
TRQ2	TRQ1																																									
0	0	Internal torque 1(parameter P145)																																								
0	1	Internal torque 2(parameter P146)																																								
1	0	Internal torque 3(parameter P147)																																								
1	1	Internal torque 4(parameter P148)																																								
14	TRQ2	Internal torque selection 2																																								
15	EMG	Emergency shutdown	OFF: Allow the servo driver to work; ON: Stop the motor according to the mode set by parameter P164.																																							
16	CMODE	Control mode switch	When parameter P004=3, 4, 5, the control mode can be switched: <table border="1" style="margin-left: 20px;"> <thead> <tr> <th>P004</th> <th>CMODE</th> <th>Control mode</th> </tr> </thead> <tbody> <tr> <td rowspan="2">3</td> <td>0</td> <td>Position</td> </tr> <tr> <td>1</td> <td>Speed</td> </tr> <tr> <td rowspan="2">4</td> <td>0</td> <td>Position</td> </tr> <tr> <td>1</td> <td>Torque</td> </tr> <tr> <td rowspan="2">5</td> <td>0</td> <td>Speed</td> </tr> <tr> <td>1</td> <td>Torque</td> </tr> </tbody> </table>	P004	CMODE	Control mode	3	0	Position	1	Speed	4	0	Position	1	Torque	5	0	Speed	1	Torque																					
P004	CMODE	Control mode																																								
3	0	Position																																								
	1	Speed																																								
4	0	Position																																								
	1	Torque																																								
5	0	Speed																																								
	1	Torque																																								

Ordinal	Symbol	DI Function	Functional explanation															
17	GAIN	Gain switch	When parameter P208=2, switch gain combination through GAIN: OFF: 1st gain; ON: 2nd gain.															
18	GEAR1	Electronic gear selection 1	GEAR1 and GEAR2 combined selection command pulse electronic gear molecules 1-4: <table border="1"> <thead> <tr> <th>GEAR2</th> <th>GEAR1</th> <th>Electron gear molecule N</th> </tr> </thead> <tbody> <tr> <td>0</td> <td>0</td> <td>1st numerator(parameterP029)</td> </tr> <tr> <td>0</td> <td>1</td> <td>2nd numerator(parameterP031)</td> </tr> <tr> <td>1</td> <td>0</td> <td>3rd numerator(parameterP032)</td> </tr> <tr> <td>1</td> <td>1</td> <td>4th numerator(parameterP033)</td> </tr> </tbody> </table>	GEAR2	GEAR1	Electron gear molecule N	0	0	1 st numerator(parameterP029)	0	1	2 nd numerator(parameterP031)	1	0	3 rd numerator(parameterP032)	1	1	4 th numerator(parameterP033)
GEAR2	GEAR1	Electron gear molecule N																
0	0	1 st numerator(parameterP029)																
0	1	2 nd numerator(parameterP031)																
1	0	3 rd numerator(parameterP032)																
1	1	4 th numerator(parameterP033)																
19	GEAR2	Electronic gear selection 2																
20	CLR	Position deviation clearing	Clear the position deviation counter. The clearing mode is selected by parameter P163. The position deviation clearing occurs at: P163=0: CLR ON level; P163=1: CLR rising edge (OFF to ON moment).															
21	INH	Pulse input inhibit	OFF: Position command pulse is allowed to pass; ON: Position command pulse is inhibited.															
22	PC	Proportional control	OFF: Speed loop PI control; ON: Speed loop P control.															
23	GOH	Homing trigger	Start the homing function. Refer to the description of parameter P178 and chapter 4.8.															
24	REF	Homing reference point	Homing external reference point, refer to the description of parameter P179 and chapter 4.8.															
37	ZEROS ET	Home settings☆	Set the current position as home (valid only with multi-turn absolute value encoder).															

5.3 DO function details

Ordinal	Symbol	DO Function	Functional explanation
0	OFF	Always invalid	Force output OFF.
1	ON	Always valid	Force output ON.
2	RDY	Servo ready	OFF: Servo main power supply is off, or alarm occurs; ON: Servo main power supply is normal, no alarm occurs.
3	ALM	Alarm	OFF: Alarm occurs; ON: No alarm occurs.
4	ZSP	Zero speed	OFF: Motor speed is higher than parameter P160 (in CCW or CW); ON: Motor speed is lower than parameter P160 (in CCW or CW).
5	COIN	Positioning complete	In position control mode OFF: Position deviation is bigger than parameter P150; ON: Position deviation is smaller than parameter P150.
6	ASP	Arrival speed	OFF: Motor speed is lower than parameter P154; ON: Motor speed is higher than parameter P154. With polarity setting function, refer to the description of parameter P154.
7	ATRQ	Arrival torque	OFF: Motor torque is lower than parameter P157; ON: Motor torque is higher than parameter P157. With polarity setting function, refer to the description of parameter P157.
8	BRK	Electromagnetic brake	OFF: Electromagnetic brake braking; ON: Electromagnetic brake is released.
10	NEAR	Near positioning	In position control mode OFF: Position deviation is bigger than parameter P152; ON: Position deviation is smaller than parameter P152.
11	TRQL	In torque limit	OFF: Motor torque does not reach the limit value; ON: Motor torque reaches the limit value. The torque limit method is set by parameter P064.
12	SPL	In speed limit	Torque control mode: OFF: Motor speed does not reach the limit value; ON: Motor speed reaches the limit value. The speed limit method is set by parameter P077.
13	HOME	Homing complete	After homing, output ON. Refer to chapter 4.8 for specific timing.
16	DBC	Dynamic braking	OFF: External dynamic brake is invalid; ON: External dynamic brake takes effect.

Chapter 6 Communication functions

6.1 Communication hardware interface

Servo drive

It has RS-485 serial communication function. Using MODBUS protocol, it can realize servo system drive, parameter change, servo system status monitoring and other functions.

It has USB communication function. It needs to be used together with PC software to change parameters. Please refer to PC software instructions and other relevant documents for specific information.

6.2 Communication parameter

Refer to section 5.1.4.

6.3 MODBUS communication protocol

When using RS-485 serial communication, each servo driver must set its servo driver station number on parameter P300 in advance. The computer or host controller communicates with the corresponding servo driver according to the station number. The communication baud rate needs to refer to the communication parameters of the host controller to set the driver P301 parameter. MODBUS can use the following two modes: ASCII (American Standard Code for information interchange) mode or RTU (Remote Terminal Unit) mode. The user can set the required communication protocol on parameter P302. The following describes MODBUS communication.

Coding meaning

- ASCII mode:

Each 8bits of data consists of two ASCII characters. For example, a 1byte data 64H(hexadecimal notation) is represented by ASCII "64", including the ASCII code of "6" (36H) and the ASCII code of "4" (34H).

ASCII code for the numbers 0 to 9 and the letters A to F, as shown in the following table:

Character sign	'0'	'1'	'2'	'3'	'4'	'5'	'6'	'7'
Corresponding ASCII code	30H	31H	32H	33H	34H	35H	36H	37H
Character sign	'8'	'9'	'A'	'B'	'C'	'D'	'E'	'F'
Corresponding ASCII code	38H	39H	41H	42H	43H	44H	45H	46H

- RTU mode:

Each 8bits data consists of two 4bits hexadecimal characters. For example: 1 byte data 64H.

Character structure:

10bits character frame (used for 8bits character without verification)

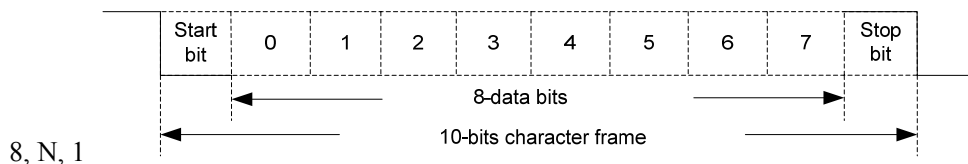

11bits character frame (used for 8bits character with verification)

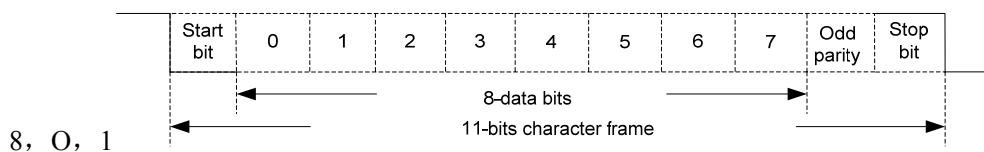
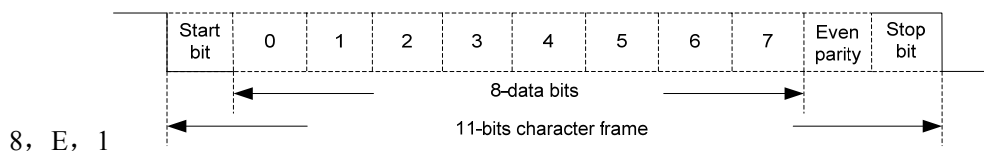

Communication data structure:

- ASCII mode:

STX	Start character ‘: ’(3AH)
ADR	Communication address: 1byte contains two ASCII codes
CMD	Command code: 1byte contains two ASCII codes
DATA(n-1)	Data content: Nword=2Nbyte, contains 4N ASCII codes, N<=100
.....	
DATA(0)	
LRC	Verification code: 1byte contains two ASCII codes
End1	End code 1: (0DH)(CR)
End0	End code 0: (0AH)(LF)

- RTU mode:

STX	The minimum time interval from the previous frame is 3.5 characters
ADR	Communication address : 1byte
CMD	Command code : 1byte
DATA(n-1)	Data content: Nword=2Nbyte, N<=100
.....	
DATA(0)	
CRC	Verification code: 2byte
End1	The minimum time interval with the next frame is 3.5 characters

The items in the communication data format box are described as follows:

1、STX (communication starting)

- ASCII mode: ':' character.
- RTU mode: The minimum time interval from the previous frame is 3.5 characters.

2、ADR (communication address)

Legal communication address ranges from 1 to 32, as shown below: communicate with the servo driver whose station number is 16 (hexadecimal 10H):

- ASCII mode: ADR='1', '0' => '1'=31H, '0'=30H
- RTU mode: ADR = 10H

3、CMD (command code) and DATA (data character)

The format of data characters depends on the command code. Common command codes are described as follows:

(1) Command code 03H, could read N words (16bit). N max. 100.

For example, two parameters are read continuously from the No. 5 parameter of section 0 of the 01H servo driver.

- ASCII mode:

Command information:

STX	':'
ADR	'0'
	'1'
CMD	'0'
	'3'
Initial data position	'0'
	'0'
	'0'
	'5'
Data number	'0'
	'0'
	'0'
	'2'
LRC Check	'F'
	'5'
End1	'0DH'(CR)
End0	'0AH'(LF)

Respond information:

STX	':'
ADR	'0'
	'1'
CMD	'0'
	'3'
Data number (count by byte)	'0'
	'4'
Section 0 number 5 parameter content	'0'
	'0'
	'2'
Section 0 number 6 parameter content	'8'
	'0'
	'C'
LRC Check	'8'
	'D'
LRC Check	'D'
	'A'
End1	'0DH'(CR)
End0	'0AH'(LF)

● RTU mode:

Command information:

ADR	01H
CMD	03H
Initial data position	00H (high byte)
	05H (low byte)
Data number	00H (high byte)
	02H (low byte)
CRC Low	D4H (high byte)
CRC High	0AH (low byte)

Respond information:

ADR	01H
CMD	03H
Data number(count by byte)	04H
0 section number 5 parameter content	00H (high byte)
	28H (low byte)
0 section number 6 parameter content	00H (high byte)
	C8H (low byte)
CRC Low	7BH (high byte)
CRC High	ADH (low byte)

(2) Command code 06H, write 1 parameter, N max. 100.

For example, write 100 (0064H) to the No.05 parameter of section 0 of the servo driver whose station number is 01H.

● ASCII mode:

Command information:

STX	‘:’
ADR	‘0’
	‘1’
CMD	‘0’
	‘6’
Initial data position	‘0’
	‘0’
	‘0’
	‘5’
Data content	‘0’
	‘0’
	‘6’
	‘4’
LRC Check	‘E’
	‘A’
End1	‘0DH’(CR)
End0	‘0AH’(LF)

Respond information:

STX	‘:’
ADR	‘0’
	‘1’
CMD	‘0’
	‘6’
Initial data position	‘0’
	‘0’
	‘0’
	‘5’
Data content	‘0’
	‘0’
	‘6’
	‘4’
LRC Check	‘E’
	‘A’
End1	‘0DH’(CR)
End0	‘0AH’(LF)

- RTU mode: :

Command information: Respond information:

ADR	01H	ADR	01H
CMD	06H	CMD	06H
Initial data position	00H (high byte)	Initial data position	00H (high byte)
	05H (low byte)		05H (low byte)
Data content	00H (high byte)	Data content	00H (high byte)
	64H (low byte)		64H (low byte)
CRC Low	98H (high byte)	CRC Low	98H (high byte)
CRC High	20H (low byte)	CRC High	20H (low byte)

Every operational parameter is only limited to the same parameter section. Different parameter section needs to be operated respectively.

4、LRC (ASCII mode) and CRC (RTU mode) frame check calculation:

- LRC frame check:

ASCII mode adopts LRC (Longitudinal Redundancy Check) frame check. LRC calculation adds all 8 bit bytes in the message from ADR to the last data content, ignores carry, and then calculates its binary complement. (For example, if the result after adding is 128H in hexadecimal, only 28H is taken), then calculate its binary complement, and then the result is LRC frame check.

For example, read the No.05 parameter of section 0 of the servo driver with station No.01H.

STX	‘: ’
ADR	‘0’
	‘1’
CMD	‘0’
	‘3’
Initial data position	‘0’
	‘0’
	‘0’
	‘5’
Data number	‘0’
	‘0’
	‘0’
	‘2’
LRC Check	‘F’
	‘5’
End1	‘0DH’(CR)
End0	‘0AH’(LF)

LRC calculation process is as follows: $01H+03H+00H+05H+00H+02H=0BH$. The binary complement of 0BH is F5H, so LRC is ' F ', '5'.

- RTU mode:

RTU mode adopts CRC (Cyclical Redundancy Check) frame check. The CRC frame check calculation is described in the following steps:

Step 1: Initialize a 16bit register containing FFFFH, called CRC register.

Step 2: XOR the first byte of the command information with the low byte of the 16 bits CRC register, and save the result back to the CRC register.

Step 3: Check the lowest bit (LSB) of CRC register. If this bit is 0, move it right by one bit. If this bit is 1, the CRC register value is shifted one bit to the right, and then XOR with A001H is performed.

Step 4: Go back to step 3 until step 3 has been executed 8 times, and then go to step 5.

Step 5: Repeat steps 2 to 4 for the next byte of the command information until all the bytes have completed the above processing. At this time, the content of the CRC register is the CRC frame check.

Note: After CRC frame check is calculated, the low bit of CRC must be filled in first, and then the high bit of CRC must be filled in the command information. Please refer to the following example.

For example, read the No. 05 parameter of section 0 of the servo driver with station No.01H. The last content of CRC register calculated from ADR to the last byte of data is 3794H, and its command information is as follows. Note that byte 94H should be transmitted before byte 37H.

ADR	01H
CMD	03H
Initial data position	00H (high byte)
	05H (low byte)
Data number	00H (high byte)
	02H (low byte)
CRC Low	D4H (high byte)
CRC High	0AH (low byte)

5、End 1, End 0 communication end:

- ASCII mode: 0DH, i.e. characters '\r' and 0AH, i.e. characters '\n', represent the end of communication.
- RTU mode: the minimum time interval with the next frame is 3.5 characters.

6.4 Write in and read out parameters

For all parameters of the servo driver, please refer to the parameter chapter. The parameters are divided according to the parameter section. Each parameter is represented by 16 bits data. The communication address of each parameter is determined by the parameter section number and parameter sequence number in the section. The address is 16 bits, the parameter section number is the high 8 bits of the address. The sequence number in parameter section is low 8bits of the address. For example, the communication address of parameter P330 is $3 \times 256 + 30 = 798$, and so on for other parameters.

Description of parameter format that can be written in and read out through the communication station (refer to chapter 6.6 for state quantity monitoring): the parameters of read out and write in must be decimal integer numbers. The parameters with decimal points are marked on the driver display panel and in the instruction manual. During the read out and write in operation, the corresponding multiples are magnified to make them decimal integer numbers. The parameter in binary format is displayed, and the decimal integer number actually used in the read out and write in operation is its equivalent. The details are as follows. See the description in the parameter section of the instruction manual for the transformation mode of each parameter:

Parameter No	Instruction manual display value	Communication operation value	Transformation mode
P005	40	40	invariant
P006	20.0	200	Magnify by 10 times
P007	1.00	100	Magnify 100 times
P120	00000(binary system)	0(decimal)	Binary to decimal

All parameters described in the parameter section can be read out and written in through communication. For details, please refer to Chapter 5 Parameters of the Description.

6.5 Common operation commands

The internal parameters of the servo driver can be read and written through the RS-485 communication port. After reading and writing, the driver parameter list can be operated as a whole through specific operation commands.

First, write the operation code to the operation command code register. After a certain delay time, read the operation status register. Reading a specific value indicates the successful completion of the operation. The operation address is as follows:

Operation register description	Contact address	Data size
Operation command code register	1100H	16bit
Operation status register	1101H	16bit

The command codes supported by the current version include "parameter operation is valid", "parameter write in EEPROM", and "Restore default value". The specific description of each command code is as follows:

Command code description	Command code	Completion status	Operation meaning
Parameter operation	BB00H	44FFH	Indicates that the modified parameter in the parameter list will take effect
Parameter write in EEPROM	0011H	FFEEH	Indicates that the parameter in the parameter list are write in EEPROM
Restore default value	0024H	FFDBH	Indicates that the default values of all parameters are read into the parameter list
Encoder reset	F024H	24F0H	Indicates that the multi-turn position is cleared and takes effect after power failure
Encoder alarm clearing	F025H	25F0H	Indicates that the encoder alarm is cleared

6.6 State quantity monitoring

The internal state quantity of the servo driver can be read out through the RS-485 communication port and cannot be written in. The state quantity is stored as 16 bit data, and the value accurate to the decimal place will be magnified by 10 times and 100 times when it is read out through the communication port. This situation is the same as the parameter reading part. The organization order of related state quantity is as follows:

1000H:	Motor speed, unit “r/min”;
1001H:	Initial position command (input pulse) low 16 bit;
1002H:	Initial position command (input pulse) high 16 bit;
1003H:	Position command (input pulse) low 16 bit;
1004H:	Position command (input pulse) high 16 bit;
1005H:	Current position (input pulse) low 16 bit;
1006H:	Current command (input pulse) high 16 bit;
1007H:	Positional deviation (input pulse) low 16 bit;
1008H:	Positional deviation (input pulse) high 16 bit;
1009H:	Motor torque, unit “%”;
100AH:	Peak torque, unit “%”;
100BH:	Motor current, unit “A”;
100CH:	Peak current, unit “A”;
100DH:	Position command pulse frequency, unit “kHz”;
100EH:	Speed command, unit “r/min”;
100FH:	Torque command, unit “%”;
1010H:	Speed analog command voltage, unit “mV”;
1011H:	Torque analog command voltage, unit “mV”;
1012H:	Input terminal DI state, note 1;
1013H:	Output terminal DO state, note 2;
1014H:	Rotor absolute position (single turn);
1015H:	Rotor absolute position (multi turn);
1016H:	Accumulative load rate, unit “%”;
1017H:	Regenerative brake load rate, unit “%”;
1018H:	Alarm code;
101AH:	Busbar voltage, unit “V”;
101BH:	Module internal temperature, unit “°C”;
101CH:	Multi-turn position (when there is no multi-turn information, read out value 0).

Note 1: The data read out by this address is 16bit, of which bit4~bit0 mean the input state of DI5~DI1. “1” means to input high level, “0” means to input low level; bit15~bit5 are stored for usage in future.

Note 2: The data read by this address is 16bit, of which bit2~bit0 mean the output state of DO3~DO1. “1” means to output high level, “0” means to output low level; bit15~bit3 are stored for usage in future.

Chapter 7 Alarm

7.1 Alarm causes and handling

In this operating instructions, “☆” means the special function of absolute encoder. “★” means the special function of incremental encoder. For software versions above V13.49, the incremental encoder is canceled.

Err 1 (Over speed)

Potential cause	Check	Handle
Motor U、V、W connection is not correct	Check U、V、W wiring	Connect the U、V、W wires correctly and correspond to the U、V、W marks of the driver plug one by one
Motor speed overshoot	Check the operation status and parameters	Adjust the servo gain to reduce the overshoot; In speed control mode can increase acceleration/deceleration time
Encoder wiring error	Check encoder wiring	Correct wiring.

Err 2 (Main circuit over-voltage)

Potential cause	Check	Handle
Input AC power supply is too high	Check the power supply voltage	Make the voltage meet the product specification
Regenerative braking failure	Whether regenerative braking resistance and brake pipe fail or wiring is disconnected	Repair.
Excessive regenerative braking energy	Check the brake load rate	<ul style="list-style-type: none"> ● Reduce start and stop frequency ● Increase acceleration/deceleration time ● Reduce torque limit ● Reduce load inertia ● Replace higher power driver and motor ● Replace the larger brake resistance

Err 4 (Position deviation)

Potential cause	Check	Handle
Motor U、V、W connection is not correct	Check U、V、W wiring	Connect the U、V、W wiring of the motor correctly and correspond to the U、V、W marks of the driver plug one by one
Encoder zero point variation	Check encoder zero point	Reinstall the encoder and adjust the zero point
Encoder wiring error	Check encoder wiring	Correct wiring
Motor stuck	Check the motor and mechanical connection	Repair
Command pulse frequency too high	Check input frequency and pulse division and multiplication parameters	<ul style="list-style-type: none"> ● Reduce input frequency ● Adjust pulse frequency division and multiplication parameters
Position loop gain is too small	Check parameter P009	Increase position loop gain
Deviation detection range is too small	Check parameter P080	Increase the value of parameter P080
Insufficient torque	Check torque	<ul style="list-style-type: none"> ● Increase torque limit ● Increase position command smoothing filter time ● Reduce load ● Replace higher power drive and motor

Err 6 (Limit alarm)

Potential cause	Check	Handle
This alarm is output when hard limit switch or soft limit position is encountered	Check whether it touches the limit switch or the soft limit value	<ul style="list-style-type: none"> ● Adjust the position of the servo motor and move out of the limit interval or soft limit parameter value

Err 7 (Drive inhibition abnormal)

Potential cause	Check	Handle
When the servo enable, CCWL、CWL drive inhibit inputs are invalid	Check CCWL、CWL wiring	<ul style="list-style-type: none"> ● Correctly input CCWL、CWL signal ● If CCWL、CWL signal are not used, set parameter P097 to shield

Err 8 (Position deviation counter overflow)

Potential cause	Check	Handle
Motor stuck	Check the motor and mechanical connection	Repair.
Abnormal command pulse	Check pulse command	

Err11 (Power module over-current)

Potential cause	Check	Handle
Motor wiring U、V、W short circuit	Check U、V、W wiring	Correctly connect U、V、W wiring
Motor winding insulation damage	Check the motor	Replace the motor
Driver damaged	Check driver	There is no problem with the motor. If the motor is powered on again or the alarm is given, the driver may be damaged. Replace the driver
Poor grounding	Check the grounding wire	Correct grounding
Disturbed	Check interference source	Add line filter to keep away from interference source

Err12 (Over-current)

Potential cause	Check	Handle
Motor wiring U、V、W short circuit	Check U、V、W wiring	Correctly connect U、V、W wiring
Motor winding insulation damage	Check the motor	Replace the motor
Driver damaged	Check driver	There is no problem with the motor. If the motor is powered on again or the alarm is given, the driver may be damaged. Replace the driver

Err13 (Over-load)

Potential cause	Check	Handle
Continuous operation over rated load	Check load rate	Reduce the load or replace with a higher power driver
System instability	Check whether the motor is oscillating	Reduce system gain
Acceleration and deceleration are too fast	Check whether the motor runs smoothly	Increase acceleration and deceleration time
Encoder zero point variation	Check encoder zero point	Reinstall the encoder and adjust the zero point

Err14 (Braking peak power overload)

Potential cause	Check	Handle
High input AC power	Check the power supply voltage	Make the voltage meet the product specification
Regenerative braking fault	Whether regenerative braking resistance and brake pipe fail or wiring is disconnected	Repair
Excessive regenerative braking energy	Check the brake load rate	<ul style="list-style-type: none"> ● Reduce start and stop frequency ● Increase acceleration and deceleration time ● Replace higher power driver and motor ● Replace the larger brake resistance
Wiring error	<ul style="list-style-type: none"> ● Whether B1 and B2 are not short circuited ● Check whether the driver model needs to be connected with external braking resistor 	<ul style="list-style-type: none"> ● Short circuit B1 and B2 ● Use for connecting external braking resistor

Err16 (Motor thermal overload)

Potential cause	Check	Handle
Long time operation over rated load	Check load rate and motor temperature rise	Reduce the load or replace with a higher power driver
Encoder zero point variation	Check encoder zero point	Reinstall the encoder and adjust the zero point

Err17 (Average braking power overload)

Potential cause	Check	Handle
High input AC power	Check the power supply voltage	Make the voltage meet the product specification
Excessive regenerative braking energy	Check the brake load rate	<ul style="list-style-type: none"> ● Reduce start and stop frequency ● Increase acceleration and deceleration time ● Reduce torque limit ● Reduce load inertia ● Replace higher power driver and motor ● Replace the larger brake resistance

Err18 (Power module overload)

Potential cause	Check	Handle
Long time operation over rated load	Check current	Reduce the load or replace with a higher power driver
Encoder zero point variation	Check encoder zero point	Reinstall the encoder and adjust the zero point

Err20 (EEPROM Error)

Potential cause	Check	Handle
EEPROM chip damaged	Power on again for inspection	If the fault persists, replace the driver

Err21 (Logic circuit error)

Potential cause	Check	Handle
Control circuit fault	Power on again for inspection	If the fault persists, replace the driver

Err23 (AD conversion error)

Potential cause	Check	Handle
Current sensor and connector problems	Check the main circuit	Replace the driver
AD converter and analog amplifier circuit problems	Check the control circuit	Replace the driver

Err24 (Under voltage of control power supply)

Potential cause	Check	Handle
Control circuit LDO fault	Check the power supply of the control board	Replace the driver

Err27 (Phase loss alarm)

Potential cause	Check	Handle
Phase loss of power supply	Check L1、L2、L3 wiring	Correct wiring
Power supply undervoltage	Check supply power voltage	Ensure correct voltage input
Phase loss checking return circuit error	Check optocoupler, power on again	If the fault persists, replace the driver

Err29 (Torque overload alarm)

Potential cause	Check	Handle
Unexpected large load occurs	Check load condition	Adjust the load
Parameters P070、P071、P072 are set unreasonably	Check parameters	Adjust the parameters

Err30 (Encoder Z signal loss) ★

Potential cause	Check	Handle
Encoder problem	Check encoder Z signal	Replace the encoder
Encoder cable and connector problems	Check cables and connectors	Replace cables and connectors

Err31 (Encoder UVW signal error)

Potential cause	Check	Handle
Encoder problem	<ul style="list-style-type: none"> ● Wrong number of wires and poles ● Encoder UVW signal error ● Encoder damaged 	Replace the encoder

Err32 (Illegal encoding of encoder UVW signal)

Potential cause	Check	Handle
Encoder problem	Check encoder UVW signal	Replace the encoder

Err35 (Inter board connection failure)

Potential cause	Check	Handle
Flat cable failure of inter board connection	Check the flat wire and its terminals	If the fault persists, replace the driver
Connection path failure	Check the optocoupler	If the fault persists, replace the driver

Err36 (Fan alarm)

Potential cause	Check	Handle
Cooling fan failure	Check the fan	Replace the fan
Fan detection circuit fault	Check wiring	Correct wiring
Fan detection circuit fault	Check the optocoupler	If the fault persists, replace the driver

Err40 (Encoder communication error)

Potential cause	Check	Handle
Encoder wiring error	Check encoder wiring	Correct wiring
Poor encoder cable and connector	Check cables and connectors	Replace cable and connector
Encoder damaged	Check encoder	Replace encoder

Err42 (Encoder internal count error) ☆

Potential cause	Check	Handle
Poor encoder cable and connector	Check cables and connectors	Replace cable and connector
Encoder damaged	Check encoder	Replace encoder

Err43 (Encoder communication responds error)

Potential cause	Check	Handle
Poor encoder cable and connector	Check cables and connectors	Replace cable and connector
Encoder damaged	Check encoder	Replace encoder

Err 44 (Encoder verify error)

Potential cause	Check	Handle
Poor encoder cable and connector	Check cables and connectors	Replace cable and connector
Encoder damaged	Check encoder	Replace encoder

Err45 (Encoder EEPROM error)

Potential cause	Check	Handle
Poor encoder cable and connector	Check cables and connectors	Replace cable and connector
Encoder EEPROM is damaged	Check encoder	Replace encoder

Err46 (Encoder parameter error)

Potential cause	Check	Handle
Poor encoder cable and connector	Check cables and connectors	Replace cable and connector
Encoder EEPROM is damaged	Check encoder	Replace encoder

Err47 (Absolute encoder external battery error) ☆

Potential cause	Check	Handle
External battery out of power	External battery voltage	Replace the battery
Power on for the first time after replacing the battery	Battery voltage	If the voltage is normal, please restart the encoder, refer to chapter 3.6.1

Err48 (Absolute encoder external battery alarm) ☆

Potential cause	Check	Handle
External battery out of power	External battery voltage	Replace the battery
Power on for the first time after replacing the battery	Battery voltage	If the voltage is normal, please restart the encoder, refer to chapter 3.6.1

Err50 (Motor parameter does not match driver)

Potential cause	Check	Handle
Motor and drive power mismatch	Check the motor adaptation table of the driver	Replace the appropriate drive or motor

Chapter 8 Specifications

8.1 Driver model

EP1C Plus - T L 05 - F0 S0 M

Mark	Main circuit supply voltage
L	AC220V
H	AC380V

Mark	Communication protocol
M	Support MODBUS
C	Support CAN

Mark	Output Power	Mark	Output Power
TL01	0.1kW	TH10	1.0kW
TL02	0.2kW	TH15	1.5kW
TL05	0.5kW	TH20	2.0kW
TL08	0.8kW	TH30	3.0kW
TL10	1.0kW	TH50	5.0kW
TL15	1.5kW	TH75	7.5kW
TL25	2.5kW	TH90	9.0kW
TL35	3.5kW	TH110	11.0kW
TL55	5.5kW	TH150	15.0kW
TH06	0.6kW		

Mark	Control mode
S0	Standard 5V differential signal input
S3	Standard 24V single-ended signal input
S8	SIEMENS CNC system professional models

Mark	Encoder type
F0	Incremental encoder
E3	Serial encoder

8.2 Driver size

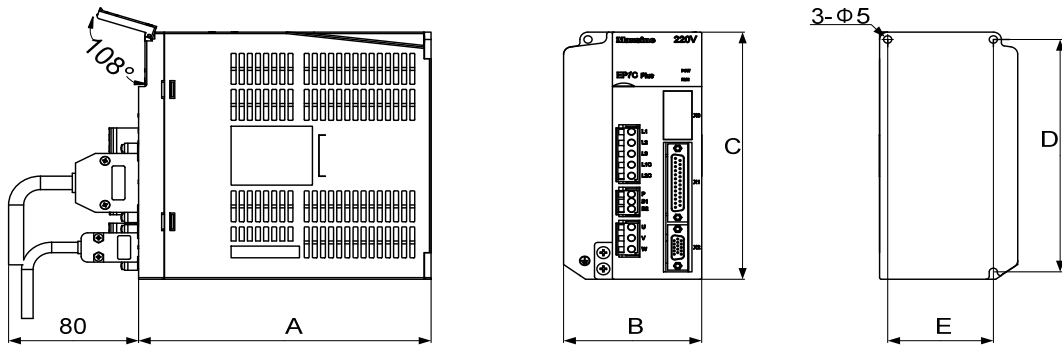

Model	TL01	TL02	TL05	TL08	TL10	TL15	TL25	TL35	TL55
Size (mm)									
A	150	150		180	180	180	180	180	210
B	55	65		75	85	95	105	105	115
C	168	168		168	168	200	220	220	250
D	158	158		158	158	189	209	209	239
E	—	55		65	65	84	94	94	104

Model	TH06	TH10	TH15	TH20	TH30	TH50	TH75
Size (mm)							
A		180		180	180		210
B		95		95	105		115
C		168		200	220		250
D		158		189	209		239
E		65		84	94		104

TH90 installation dimension drawing

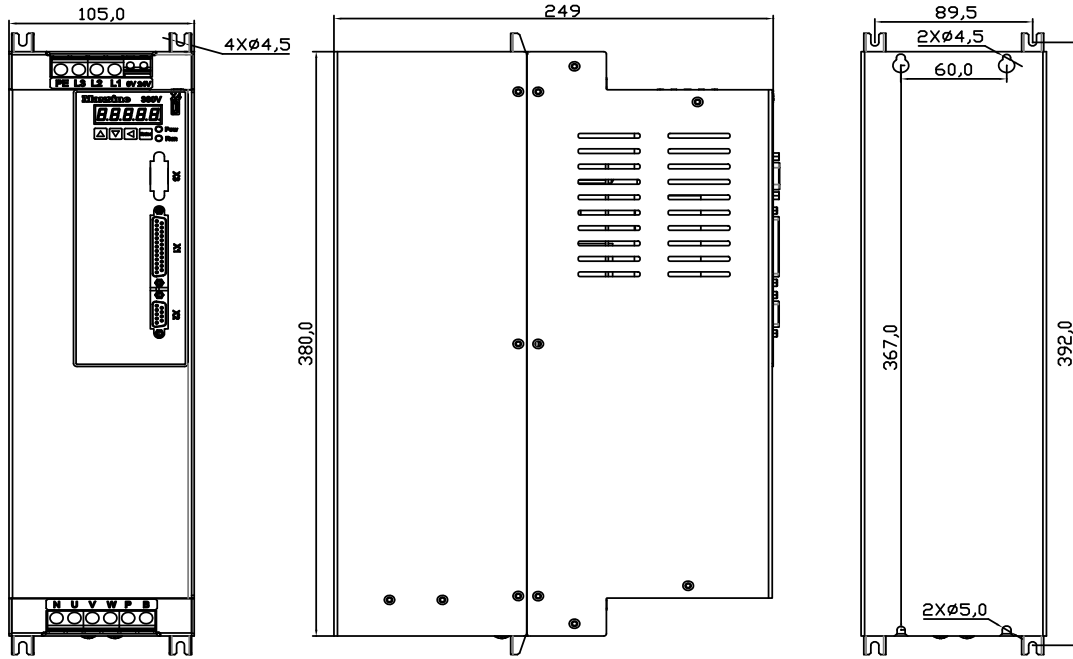

TH110、TH150 installation dimension drawing

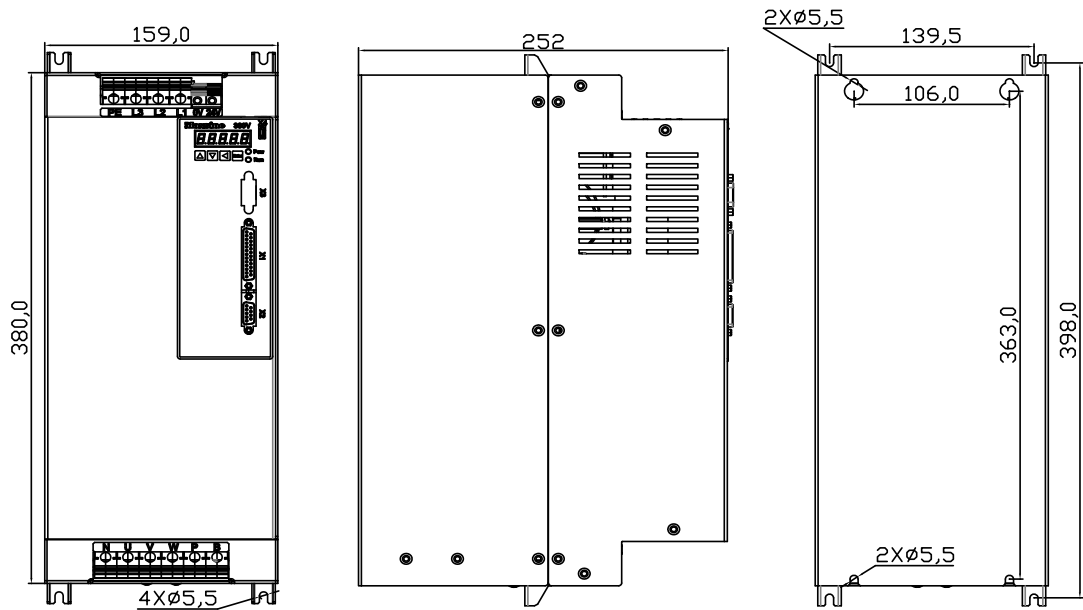

8.4 Motor adaptation table of the driver

Motor model (220V series)	Torque N·m	Speed r/min	Power kW	Recommend adaptation	adaptable
40MSL00330	0.32	3000	0.10	TL01	
60MSL00630	0.64	3000	0.20	TL02	
60MSL01330	1.27	3000	0.40	TL05	
80MSL01330	1.27	3000	0.40	TL05	
80MSL02430	2.39	3000	0.75	TL08	TL10
80MSL03230	3.18	3000	1.00	TL10	
110MSL03225	3.18	2500	0.83	TL10	TL15
110MSL04825	4.77	2500	1.25	TL15	
110MSL06425	6.37	2500	1.67	TL15	
110MAL04030	4.00	3000	1.26	TL15	
110MAL05030	5.00	3000	1.57	TL15	
110MAL06030	6.00	3000	1.88	TL15	
130MSL04025	4.00	2500	1.00	TL10	TL15
130MSL04820	4.77	2000	1.00	TL10	TL15
130MSL05025	5.00	2500	1.30	TL15	TL10
130MSL07220	7.16	2000	1.50	TL15	TL25
130MSL09620	9.55	2000	2.00	TL25	TL35
130MSL10025	10.00	2500	2.60	TL25	
130MSL14320	14.30	2000	3.00	TL35	TL55
130MAL06025	6.00	2500	1.57	TL15	
130MAL07725	7.70	2500	2.02	TL25	TL15
130MAL10015	10.00	1500	1.57	TL15	
130MAL15015	15.00	1500	2.36	TL25	
130GSL05415	5.39	1500	0.85	TL15	TL10
130GSL08315	8.34	1500	1.30	TL25	TL15
130GSL11515	11.50	1500	1.80	TL25	TL35
130GSL15015	15.00	1500	2.36	TL35	TL25
130GAL05415	5.39	1500	0.85	TL10	TL15
130GAL08315	8.34	1500	1.30	TL15	TL25
130GAL11515	11.50	1500	1.80	TL25	TL15
130GAL15010	15.00	1000	1.50	TL15	TL25
130GAL15015	15.00	1500	2.36	TL25	TL35

Motor model (380V series)	Torque N·m	Speed r/min	Power kW	Recommend adaptation	adaptable
110MAH04030	4.00	3000	1.26	TH15	TH10
110MAH05030	5.00	3000	1.57	TH15	
110MAH06030	6.00	3000	1.88	TH15	TH20
130MAH04025	4.00	2500	1.00	TH10	
130MAH04820	4.77	2000	1.00	TH10	
130MAH05025	5.00	2500	1.30	TH15	TH10
130MAH06025	6.00	2500	1.57	TH15	
130MAH07725	7.70	2500	2.02	TH20	
130MAH10015	10.00	1500	1.57	TH15	
130MAH15015	15.00	1500	2.36	TH30	
180MAH19015	19.00	1500	3.00	TH30	
180MAH27015	27.00	1500	4.30	TH50	
180MAH35015	35.00	1500	5.50	TH75	TH50
180MAH48015	48.00	1500	7.50	TH90	TH75

8.5 Servo motor model

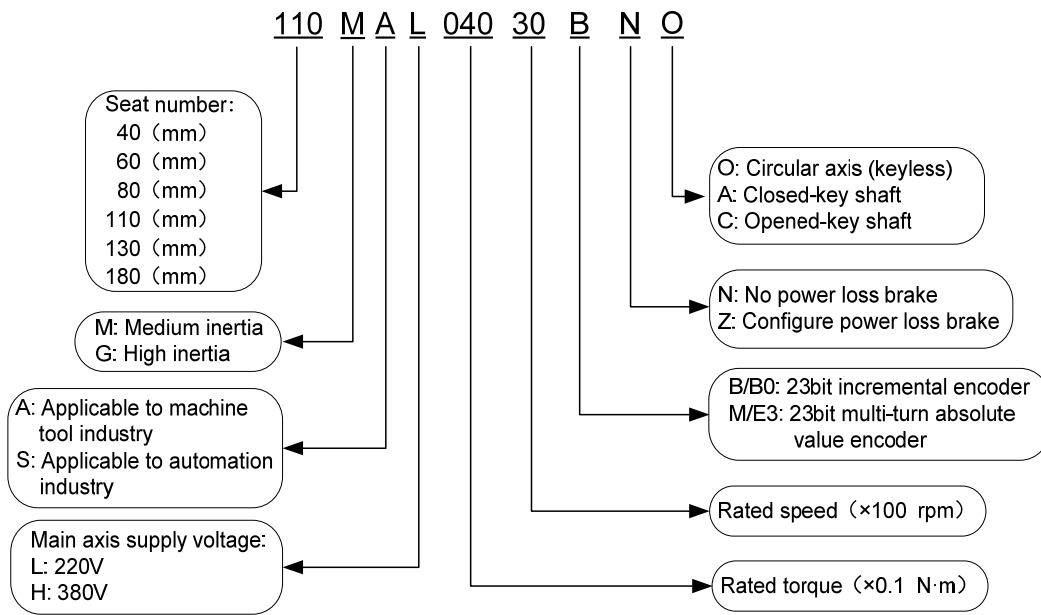

8.6 Servo motor wiring

8.6.1 Winding wiring

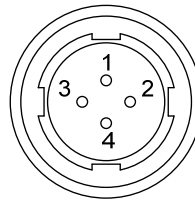
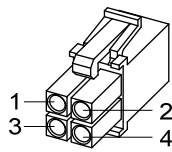

40/60/80 motor power supply plug 110/130/180 motor power supply plug

Terminal symbol	Terminal number		Terminal description
	40/60/80 motor	110/130/180 motor	
U	1	2	Motor U phase power input
V	2	3	Motor V phase power input
W	3	4	Motor W phase power input
⊕	4	1	Motor housing grounding terminal

8.6.2 Brake wiring

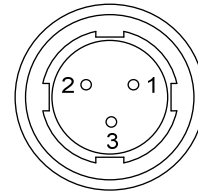
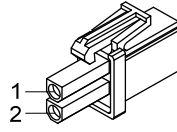
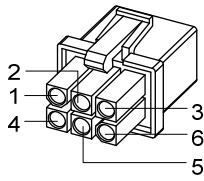

40 motor with brake power plug 60/80 motor brake plug 110/130 motor brake plug

40 motor with brake power supply wiring:

Terminal symbol	Terminal number	Terminal description
U	1	Motor U phase power input
V	2	Motor V phase power input
W	3	Motor W phase power input
PE	4	Grounding terminal
BK+	5	Brake terminal
BK-	6	

60, 80, 110, 130, 180 motor brake wiring:

Terminal symbol	Terminal number		Terminal description
	60/80 series motors	110/130/180 series motors	
DC+	1	1	Brake power supply is DC power supply with no polarity connection requirements
DC-	2	2	
PE	—	3	

8.6.3 Encoder

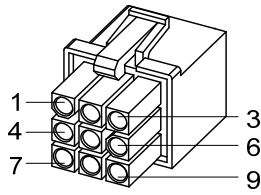

40/60/80 motor encoder plug

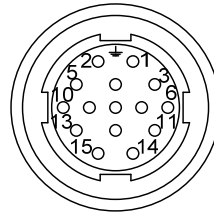

110/130/180 motor encoder plug

40、60、80、110、130、180 motor encoder wiring:

Terminal symbol	Terminal number					Terminal description
	40motor	60/80motor		110/130/180motor		
	Absolute value	Absolute value	Incremental	Absolute value	Incremental	
SD+	1	1	1	6	6	Encoder signal wire
SD-	2	2	2	7	7	
VCC	6	6	6	2	2	Encoder 5V power input
GND	7	7	7	3	3	
Battery+ ☆	3	3	---	4	---	3.6V battery powered
Battery - ☆	8	8	---	5	---	
PE	9	9	9	1	1	Ground terminal

Note: In this operating instructions, “☆” means the special function of absolute encoder. “★” means the special function of incremental encoder. For software versions above V13.49, the incremental encoder is canceled.

Edition history

Edition number	Published time	Modify content
6th edition	April, 2019	
7th edition	September, 2019	
8th edition	July, 2020	
9th edition	October, 2021	

Wuhan Maxsine Electric Co., Ltd

Address: Building A6, Hangyu Building, No.7, Wuhan University Science
Park Road, East Lake Development District, Wuhan City, Hubei
Province, China.

Zip: 430223

Company phone: 400-894-1018

Sales Tel: 400-894-1018-857/804

Sales Fax: 027-87921290

After service Tel: 400-894-1018-831/832

Website: www.maxsine.com

Published in October, 2021

Forbid to reprint and copy